

Darrell's
Copy !!!

CONSTRUCTION BARGE
HMB-1

OPERATING MANUAL

Prepared For

LOCKHEED MISSILES & SPACE COMPANY, INC.
A Subsidiary of Lockheed Aircraft Corporation

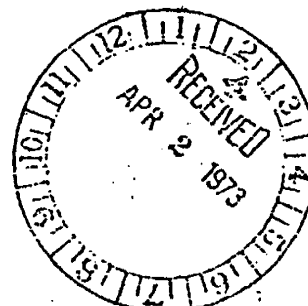

L.R. GLOSTEN & ASSOCIATES, INC.
Naval Architects - Marine Engineers - Ocean Engineers
71 Columbia Street
Seattle, Washington 98104

and

DIEHL AND LUNDGAARD, INC.
Marine Engineers
Bainbridge Island, Washington 98110

File No. 7043

February 1972
Revision A, 14 March 1972
Revision B, 24 March 1972
Revision C, 29 March 1972
Revision D, 5 April 1972
Revision E, 23 April 1973

Preface

This manual has been prepared to assist operating personnel of the construction barge HMB-1. Systems and operating procedures which are peculiar to this vessel are described, with particular attention given to the submerged mode of operation. However, a general knowledge and competence in the areas of seamanship, marine piping systems, and typical marine machinery on the part of the responsible operating personnel is assumed.

For information regarding the proper operation, repair, or maintenance of specific items of equipment within systems, refer to manufacturers' instructions.

All operating personnel should be familiar with the restrictions on operating procedures imposed by the U.S. Coast Guard as a condition of design approval and vessel certification. These restrictions are given in Section III of this manual.

T A B L E O F C O N T E N T S

I	Hull Systems	I-1
	A. General Description	I-1
	B. Hull Arrangement	I-3
	C. Compartment Nomenclature	I-3
	D. Decks	I-5
	E. Mooring	I-8
	F. Outfit List	I-9
.II	Mechanical and Electrical Systems	II-1
	A. List of Technical Manuals	
	B. Operational Diagrams, An Introduction	
	Figure 1, Ballast air supply and breakout system	
	Figure 2, Constant pressure air supply and overpressure protection system	
	Figure 3, Hydraulic system	
	Figure 4, Wet lock system	
	Figure 5, Control space pressurizing, venting, and atmospheric reference system	
	Figure 6, Soft tank flooding and blowing	
	Figure 7, Variable tank flooding and blowing	
	Figure 8, Trim transfer and filling system	
	Figure 9, Stabilizing cylinder flooding and blowing	
	Figure 10, WB reel and winch power and control	
	Figure 11, Sea water cooling system	
	Figure 12, CB winches, power, and controls	
	Figure 13, Electrical system	
	C. Introduction to Fold-outs	
	Figure 14, 4-inch ballast air, 2-inch vent, and anchor air supply	
	Figure 15, Pontoon and rake tanks, flood-blow-vent	
	Figure 16, Wing tanks, flood-blow-vent	
	Figure 17, Variable tank, flood-blow-vent	
	Figure 18, Trim tank, vent, blow, and transfer system	
	Figure 19, Stabilizing cylinders, flood, blow, and vent	
	Figure 20, Emergency drain, rake, wing, and pontoon tanks	
	Figure 21, Hydraulic lines and valves for pontoon, wing, and rake tanks	
	Figure 22, Hydraulic lines and valves for variable and trim tanks	
	Figure 23, Stabilizing cylinder hydraulic lines and valves	
	Figure 24, Fluidics	

cont'd / . . .

Table of Contents, cont'd

	Figure 25, Bottom breakout system	
	Figure 26, Sounding tube locations	
	Figure 27, Fire main	
III	Operating Restrictions and Recommendations	III-1
	A. Restrictions	III-1
	B. Recommended Operating Practices	III-3
IV	Operating Sequences	IV-1
	A. General	IV-1
	B. Summary of Ballast Tank Valve Positions	IV-1
	C. Procedure	IV-3
V	Damage Control	V-1
	Introduction to Damage Control Section	
	Equipment Failure Summary Table	
	Alarm Conditions	
	1. Entering atmospheric control space	
	2. Leaving atmospheric control space	
	3. Entering hyperbaric control space	
	4. Leaving hyperbaric control space	
	5. Control space flooding	
	6. Ballast air supply to CB cut off	
	7. Vent umbilical blocked	
	8. Fluidic and pneumatic systems inoperative	
	9. Hydraulic system inoperative	
	10. Electrical power to CB cut off	
	11. Cylinder floods accidentally during submergence	
	12. Cylinder blown accidentally on bottom	
	13. Cylinder cannot be blown on bottom	
	14. Cylinder cannot be flooded on bottom	
	15. Ballast tank does not blow	
	16. Ballast tank does not flood	
VI	Hydrostatic Characteristics and Calculations	VI-1
	A. General	VI-1
	Design Features	VI-1
	Constraints on Ballasting Sequence	VI-1
	When to Perform Calculations	VI-2
	B. Soft Tank Ballasting	VI-2
	1. Soft Tank Flooding Sequence	VI-2
	2. Blowing	VI-3
	3. Tank Capacity Curves	VI-4
	4. Calculation Forms	VI-4

cont'd / . . .

Table of Contents, cont'd

C. Hard Tank Ballasting	VI-7
1. Guidelines	VI-7
2. Description of Diving Polygons and Overlays	VI-9

I HULL SYSTEMS

A. General Description

The HMB-1 is to be designed as a construction barge and submersible drydock for support of Lockheed Ocean Systems in Oceanographic Research Operations. The drydock will support the development and testing of commercial ocean mining system hardware and will assist in the placement, testing, and recovery of offshore petroleum systems equipment. The drydock will be utilized under tow for transport of various oceanographic research equipment, as well as systems hardware to designated operation sites. Submergence of the drydock to depths of 100 to 165 feet will allow for a wider variety of research purposes, construction, maintenance, and repair of various elements of hardware associated with Lockheed's Ocean Programs.

Unusual features of the construction barge (CB) are the wing walls on both sides; curtain bulkheads across the ends of the wing walls; a roof spanning the tops of the wing walls that can be rolled open or closed even when submerged; a travelling bridge crane between the wing walls for use at dockside; remote control during submerged operations from a surface support barge; and four cylindrical floats above the wing walls connected at each corner with chain linkages. These floats are self-erecting during submergence and self-depressing during surfacing. In addition to providing buoyancy and stability, the floats will improve control after the main structure submerges.

As an ocean barge, the carrying capacity at the load line draft of 13'-11-3/8" is 6,290 long tons. The maximum carrying capacity for submerged operations with the payload located on centerline amidships is 2,500 long tons. At other locations for the payload, there is a reduction in the weight that can be lifted due to the compensation necessary to correct for list and/or trim.

CONSTRUCTION BARGE, GENERAL ARRANGEMENT

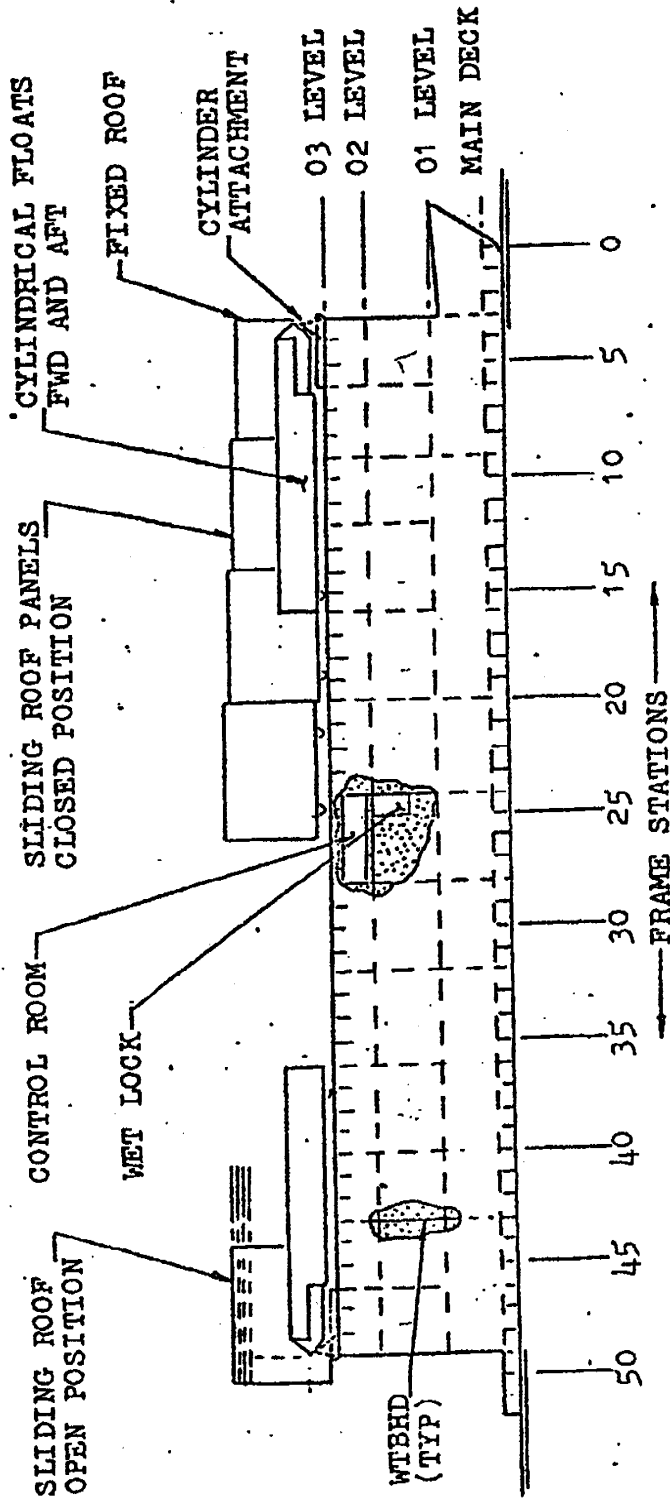

B. Hull Arrangement

The principal characteristics of the CB are as follows:

Length, overall	324'-	0"
Breadth, extreme	106'-	10"
Height, wing wall above baseline	62'-	0"
Height, main deck (centerline above baseline)	19'-	0"
Width, inside wing walls, molded	76'-	8"
Length inside wing walls	276'-	0"
Loadline draft (above bottom of keel)	13'-11-3/8"	
Loadline draft displacement	10,875	L.T.S.W.
Light Vessel displacement, estimated	4,585	L.T.S.W.

The lower "barge" hull is subdivided by three longitudinal bulkheads extending between the transverse rake bulkheads, and four additional transverse bulkheads.

The drydock-type wing walls on either side are subdivided vertically by the O1 and O2 decks, and transversely by 12 bulkheads.

All spaces below the O1 level have been designed as either free-flooding or "soft" spaces. They must be flooded completely before the CB submerges, as they will not withstand full submergence pressure.

All spaces above the O1 level are "hard" spaces which have been designed to withstand submergence depth pressure.

C. Compartment Nomenclature

All spaces on the CB have been identified by a four-part compartment number, using the conventional U.S. Navy system.

First part, deck at lower boundary of space

- 2 - bottom
- 1 - main deck
- 01 -
- 02 -

Second part

Frame number at forward boundary of space.

Third part, transverse location

- 0 - extends each side of centerline
- 1 - first space to starboard
- 2 - " " " port
- 3 - second " " starboard
- 4 - " " " port

Fourth part, type of space

- S - soft ballast tank
- B - hard ballast tank
- T - trim tank
- V - void space
- F - free-flooding space

The following is a brief description of the spaces on board and their functions.

2-10-0-S	Forward rake	treated as soft pontoon tanks in all operations. Extend from side to side of vessel, bottom to main deck.
2-49-0-S	After rake	
2-3-1&2-S	Pontoon tanks	extend from centerline to wing bulkhead P/S, and from bottom to main deck. Bounded by soft structure.
2-9-1&2-S		
2-20-1&2-S		
2-32-1&2-S		
2-43-1&2-S		
2-3-3&4-S	Wing tanks	extend from wing bulkhead to shell P/S, and from bottom to 01 deck through flood openings in main deck, except in way of midships access passage, where main deck is tight.
2-9-3&4-S		
2-20-3&4-S		
2-30-3&4-S		
2-43-3&4-S		
1-0-0-F	Forecastle	Free-flooding through side ports and arches in aft bulkhead.

1-24-1&2-F	Midships access	Free-flooding spaces in wing wall for access to main deck and up to wet lock P/S. Extend from main deck to 01 deck between frames 24 and 28. Between frames 24 and 25, they extend clear to 02 deck, with wetlocks located in top, outboard.
01-03-1&2-T 01-46-1&2-T	Trim tanks	Hard ballast tanks connected by a ring main system for changing trim or heel without changing displacement.
01-05-1&2-B 01-09-1&2-B 01-13-1&2-B 01-20-1&2-B 01-25-1&2-B 01-28-1&2-B 01-32-1&2-B 01-40-1&2-B 01-43-1&2-B	Variable Ballast tanks	These 18 tanks are fitted for taking on ballast, and are further identified in the operating instructions as VB tanks. Since they do not have level indicators, they would normally be carried completely full or completely empty during submergence.
01-12-1&2-B 01-36-1&2-B	Variable Ballast tanks	Similar to tanks listed above, except that they are <u>fitted with tank level, tank pressure, and valve position indicators.</u> These are further identified in the operating instructions as IVB or <u>instrumented variable ballast tanks.</u>
All 02 level tanks	Voids	Not fitted with means of flooding or blowing, except control spaces.
02-24-1&2-V	Control space	Fitted with means of pressurizing for damage control purposes.

D. Decks

It will be helpful to operating personnel to memorize the heights of decks and other structure above the keel, so that the elevation of the top or bottom of any tank relative to outside waterline can be determined quickly from draft.

Draft may be read from conventional draft marks or from fluidic system gauges located in the starboard control space and in the remote control station.

— Main deck, at side	18 ft —
— Main deck, at center	19 ft —
— 01 deck	33 ft —
— 02 deck	51 ft —
— 03 deck	62 ft
Top of roof, at ends	85 ft
Top of roof, center sections	90 ft
Top of cylinders, erect	146 ft 6 in.

CONSTRUCTION BARGE HMB-1

TANK ARRANGEMENT & NOMENCLATURE

TK AREAS FOR FLOODING
 IF NEEDED FOR TRIM
 TK AREAS WHICH WILL
 BE FLOODED

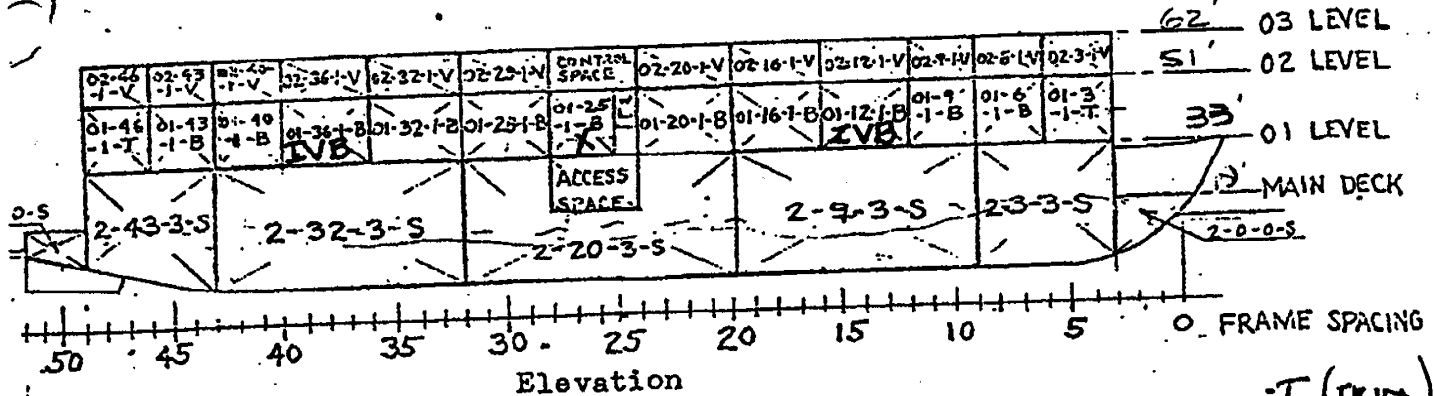

Inbd of Stbd Shell lkg Inbd -- Port Side Opposite



Plan View Above 02 Level
Port Side Shown -- Stbd Opposite

- T (TRIM)
- B (HARD BALLAS)
- S (SOFT BALLAS)
- IVB - INSTRUMENTED VARIABLE BALLAST

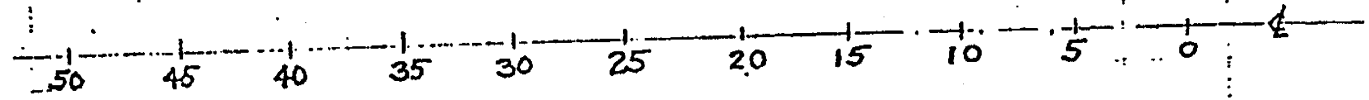

WET LOCK

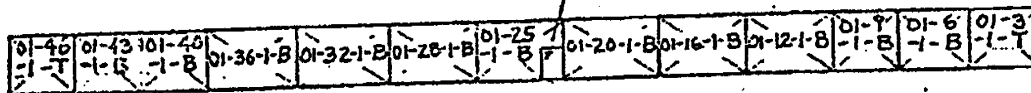

Plan View Above 01 Level
Stbd Side Shown -- Port Opposite

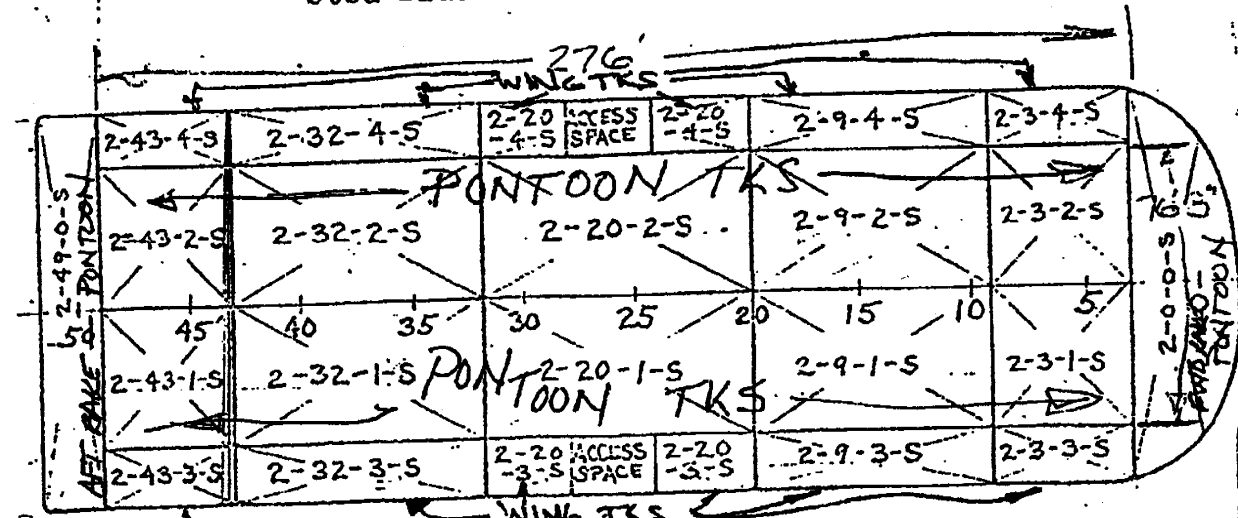

Plan View at Main Deck

I7

LOADLINE DRAFT (ABOVE BOTTOM OF KEEL) 13' 11 7/8"
 LOADLINE DRAFT DISPLACEMENT 10875 LT S.
 LIMIT VERTICAL DEP. (MT) 4555 LBS

E. Mooring

The site selection for submerging the CB will involve, among other things, considerations of the mooring arrangement, equipment, and anticipated forces that will act on the CB.

When anchoring in 160 to 165 feet of water, the two anchors should be set down approximately 600 feet apart and 400 feet ahead of the buoys marking the site. The anchor chains form an angle of 30 degrees to the centerline of the CB with 90 fathoms of chain paid out.

The surface support barge (WB) will be connected to the stern of the CB with a chain. A tugboat or anchors attached to the WB will maintain tension on the anchor chains and will keep the CB in position against opposing forces. The site should be laid out so as to minimize these opposing forces of current, tide, prevailing winds, and waves.

The anchoring equipment consists of two 6,000-pound anchors, Bal&t "snug stowing", each connected to 105 fathoms of 1-5/8-inch, Grade 3, stud-link chain. Estimated holding power of each anchor in the direction of pull of the chain is given in the following table, for use in laying out mooring arrangements for particular sites.

Bottom Condition and set	Chain Angle With Bottom, Degrees		
	0	6	12
Mud, 250 ft drag	115,000 lb	90,000 lb	80,000 lb
Mud, 50 ft drag	70,000 lb	45,000 lb	40,000 lb
Sand, 50 ft drag	90,000 lb	85,000 lb	70,000 lb

F. Outfit List

1. Towing bridle
 - 1 towplate, alloy steel, Washington Chain & Supply Co. #2
 - 3 3-inch alloy steel shackles
 - 2 2-3/4-inch, high strength, stud link chain-bridle legs (approx. 86 feet long)
 - 2 4-inch alloy steel safety shackles
 - 1 2-3/4-inch, high strength, stud link chain surge chain (approx. 35 feet long)
2. Anchors
 - 2 6,000-pound anchors, Baldt "Snug Stowing"
3. Anchor chain
 - 2 105 fathoms, 1-5/8-inch, Grade 3 stud link chain
4. Anchor chain stoppers
 - 2 pelican-hook type chain stoppers
 - 2 pawl-type chain stoppers
5. Anchor windlasses
 - 2 Markey type WAS-34 with air motor drives and manual controls, wildcat for 1-5/8-inch stud link anchor chain and one 24-inch diameter warping head
6. Fairlead blocks and shackles
7. Mooring lines
8. Navigation lights
 - 4 155mm marine signal lanterns, Tideland Signal Corp. ML-155; with automatic lamp changer and sun switch. One light with a red lens, one with a green lens, and two with white lens.
 - 3 battery packs, each consisting of two Eveready "Air Cell" batteries type T-2300 and one type T-1600 in series. Connectors, cables, stowage boxes, and light screens. The red and green side lights shall be lamped with 6.2 volt, 0.46 amp bulbs, and the white lights with 6.2 volt, 0.25 amp bulbs.
9. Electronic flash beacon
 - 1 battery-powered flash beacon, Benthos Model 2143-200, with a 50-foot long tethering line of 1/4-inch polypropylene
10. Loading boom and winches (5 Ton)
 - 1 34-foot boom, pad eyes, blocks, and rigging lines
 - 2 winches, 15 horsepower, one for hoisting and one for topping, Beebe Model 5000
 - 2 winches, 10 horsepower, for vangs, Beebe Model 2500. All four winches are air motor driven and reversible with "dead man" type control levers.
11. Fire fighting equipment
 - 6 15-pound portable carbon dioxide fire extinguishers
 - Fire hoses and nozzles
 - 4 10-pound portable, dry chemical type fire extinguishers for the control spaces

CB Outfit, cont'd

12. Travelling roof machinery
13. Surface support equipment for remote control
 - a. Electrical Umbilical Assembly (7043-56)
 - 1 850-foot long section for CB connection
 - 1 100-foot long surface section
 - 2 cable grips (one for CB and one for reel)
 - b. Fluidic Umbilical Assembly (7043-55)
 - 1 850-foot long section for CB connection
 - 1 100-foot long surface section
 - c. Electric and Fluidic Reel Assembly (7043-54)
 - 2 reels nearly identical with 6-foot diameter by 13-inch wide drum and 9-foot diameter tapered flanges, mounted on a common reel foundation designed to permit rapid removal and replacement of the reels
 - 2 reel drives, geared air motors providing 5.8 horsepower at 61 rpm at 90 psi and brakes that are spring set, air release band-type
 - d. Ballast Air Umbilical Assembly (7043-57)
 - 17 50-foot sections of 4-inch ID hoses joined by quick-disconnect couplings. Three hose sections are spares.
 - e. Vent Air Umbilical Assembly (7043-57)
 - 17 50-foot sections of 2-inch ID hoses joined by quick-disconnect couplings. Three hose sections are spares.
 - f. Air Hose Wire Rope Cables (7043-57)
 - 17 14-inch long with eye in each end used to pass through the towing chain
 - 34 wire rope tethers, one end attached to male ends of 4-inch and 2-inch diameter air hoses and the other end attached to pearsnaps with about 6 inches of wire
 - 34 arm hold-down cables to go around the quick-disconnect coupling arms on the female ends of the 4-inch and 2-inch diameter air hoses
 - g. Towing Chain Assembly
 - 725-foot length of one-inch stud link, Grade 3, galvanized chain used for connecting the surface ship to the CB
 - h. Chain Winch (7043-50)
 - 1 winch capable of storing 600 feet of one-inch stud link chain, manufactured by Markey Machinery Model DASC-16 and driven by a single radial piston air motor, EIMCO Model 272M33
 - i. Hose Storage Rack (7043-51)
 - 3 17-foot steel racks for storing the 17 4-inch and 17 2-inch, 50-foot lengths of air hoses
 - j. Chain and Hose Guide (7043-51)
 - 1 56-foot steel fabrication to provide a means of joining the umbilical hoses to the towing chain.

CB Outfit, cont'd

- k. Reel and Winch Control Station (7043-52)
 1 steel pipe and plate raised platform for the control console and operator. Control levers and gauges are provided for each umbilical reel and the towing chain winch.
 A fabric cover is provided.
- l. Remote Control Station (7043-52)
 1 portable house containing the remote control console, along with furniture, lights, ventilation, and communication equipment
- m. Compressor/Generator Station (7043-51)
 1 portable house for the two constant pressure air compressors and the two diesel generator sets along with lights, ventilation, and fuel system
- n. Remote Electrical System (7043-53)
 This is a self-generated electrical power source for the CB and its surface ship mounted equipment.
 2 10KW, 460VAC, 3 phase, 60 HZ generators, Lima Model MAC-R, powered by Lister Model SR-3 air cooled diesel engines with 12 volt electric starting systems and other accessories
 1 460 VAC electrical distribution panel with three 460VAC, 3 phase circuits. Also included are motor controllers and the station lighting transformer in this panel.
 1 transformer panel in remote control station
- o. Constant Pressure Air System (7043-51 & -53)
 This system provides 3 SCFM at 100 psig for supplying air to the CB fluidic system.
 2 electric motor-driven air compressors, Quincy Model F-210, of 3 SCFM at 120 psig, with a 30-gallon receiver, air cooled aftercoolers, one-horsepower, 440VAC, 3 phase, drip-proof electric motor, and accessories
- p. Ballast Air System (7043-50, -53, -57)
 Provides 2400 SCFM of air at 100 psig and 150°F maximum temperature for blowing ballast tanks on the CB.
 2 self-contained, diesel driven rotary type, Atlas Copco Model PT-1200; each delivers at least 1200 SCFM at 100 psig discharge pressure
 1 water cooling heat exchanger, Young Model XF-805-TR4-4P-CN-B
 1 filter/separator, Dollinger Model GP-108-210 is located downstream of the heat exchanger
- q. Sea Water System (7043-51 & -58)
 Provides water for cooling the ballast air heat exchanger.

CB Outfit, cont'd

- 1 sea water pump, Pacific Pumping Co. Type L, 1.5-inch BD, Unitype, centrifugal pump with single suction cast iron casing and bronze impeller. Pump rating is 50 gpm at 50 feet TDH and 15 feet maximum suction lift. The electric motor is a one-horsepower, 460VAC, 3 phase, 60 HZ, drip-proof motor.
- 1 15-foot length of 2-inch suction hose with inlet foot valve.
- 1 25-foot length of 1-1/2-inch hose for heat exchanger discharge
- 1 75-foot length of 1-1/2-inch hose for pump discharge
- 1 gate valve and thermometer located at heat exchanger outlet

G. Structural Design Criteria

1. Hydrostatic Loads.

An understanding of the structural characteristics of the CB is essential in determining the limits of safe operation during flooding and blowing of tanks. Table I-1 summarizes the hydrostatic loads, on various structural boundaries, which were used for design. The air test pressures used for structural proof testing during construction are also shown.

It is important to distinguish between external boundaries, such as the shell, bottom, or main deck, and internal boundaries, such as bulkheads or O2 deck. During flooding or blowing operations, an external boundary is subjected to a differential between the internal pressure of the tank and the ambient pressure outside. Internal boundaries, however, may be subjected to the full gauge pressure in a tank, if the adjacent space is at atmospheric pressure (as are the void spaces, unused hard tanks, or vented soft tanks). In some cases, the internal boundary strength can impose constraints on the operating procedure. During soft tank blowing, for instance, the strength of bulkheads determines a limiting draft at which empty tanks may be vented to atmosphere while adjacent tanks are still being blown.

TABLE I-1

SUMMARY OF DESIGN AND TEST PRESSURES*

External Boundaries

	DESIGN		TEST**
	Top of Tank	Bottom of Tank	(Air)
Pontoon and Rake Tanks	24.5	36.0	33.1
Wing Tanks	36.5	62.0	44.8
Hard Tanks	114.0	114.0	121.0

Internal Boundaries

(NOTE: All bulkheads designed for uniform head throughout height. Test pressures are as given above.)

<u>Boundaries Between:</u>	<u>Design Pressure</u>
Adjacent Pontoon Tanks	42.0
Pontoon and Wing Tanks	47.0
Adjacent Wing Tanks	67.5
Adjacent Hard Tanks	177.0

* All pressures are expressed as head of seawater, in feet.
 ** Ref: NASSCO Dwg 360-126-01.

II MECHANICAL AND ELECTRICAL SYSTEMS

A. LIST OF TECHNICAL MANUALS

Reference	Equipment
1	Fluidic system
2	Ballast air compressors
3	Constant pressure air compressors
4	Diesel generator sets
5	Sea water pump
6	Hydraulic pump, electric motor driven
7	Hydraulic pump, air driven
8	Chain winch
9	Umbilical reels
10	Vang winches
11	Hoist and topping winches
12	Anchor windlass

B. OPERATIONAL DIAGRAMS - AN INTRODUCTION

The operational diagrams illustrate major features of the CB and surface ship system. Each diagram illustrates a sub-system as simply as possible. Only the features necessary for a broad understanding of the operation are included. For system details, the reader should refer to the contract plans and working drawings.















Each operational diagram is accompanied by a text, which briefly describes the system and lists a step by step operational outline. The operational outline assumes that initially all machinery is shut down and all valves are closed, unless stated otherwise.

Instructions relating to diving procedures and diver safety are not covered in this manual.

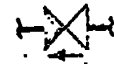
Gauges are defined by their number on the gauge list, NASSCO Drawing No. 362-200-06.

LIST OF SYMBOLS

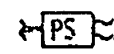
GENERAL SYMBOLS

- N.O. Normally Open
- N.C. Normally Closed
-  Float check, closes when filled with water
-  Butterfly Valve, manually operated
-  Butterfly Valve, remotely operated
-  Globe valve
-  Needle Valve
-  Pressure Control Valve
-  Gate Valve
-  Swing Check Valve
-  Lift Check Valve
-  Stop Check Valve
-  2 Way Ball Valve
-  3 Way Ball Valve
-  Pressure Gauge
-  Pressure Switch
-  Strainer, 100 Mesh Basket
-  Filter, 24 Micron Element



Filter/Moisture Separator



Float Check Valve



Thermometer

PNEUMATIC SYMBOLS

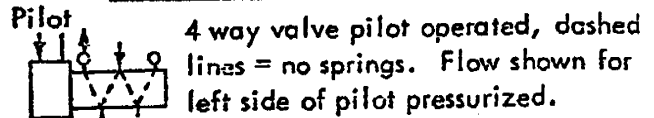

4 way valve pilot operated, dashed lines = no springs. Flow shown for left side of pilot pressurized.

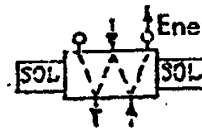

4 Way Valve, solenoid operated, no springs flow shown for right solenoid energized.

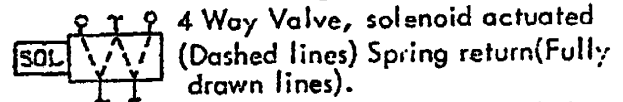

4 Way Valve, solenoid actuated (Dashed lines) Spring return (Fully drawn lines).

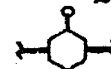

Quick Release Valve, passes air in one direction, exhausts other direction



Pressure Regulator, Manual

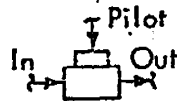

Relay Valve, output proportional to pilot signal

HYDRAULIC SYMBOLS



Shut-Off Valve

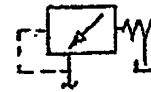

Pressure Regulating Valve



Pressure Relief Valve



Ball Check Valve

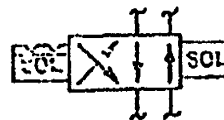

4 Way Valve, Solenoid operated w/ detents

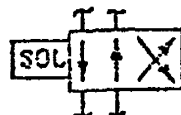

4 Way Valve, solenoid operated, spring return

FIGURE 1
BALLAST AIR SUPPLY AND BREAKOUT SYSTEM

1. DESCRIPTION

is provided by two 100 psig, 1200 scfm air compressors for the following uses:

Tank blow - Pressurizing tanks and stabilizing cylinders in order to expel ballast water.

Trim tank transfer - Pressurizing one trim tank in order to transfer water to an adjacent, vented tank.

Breakout - Distribute air between the vessel shell and the sea floor in order to break surface adherence.

Pressurizing the wet lock in order to equal inside and outside pressures.

Normal and emergency air supply to control spaces.

Power for the following air motors on the CB:

- One hydraulic pump
- Two anchor windlasses
- Various boom winches.

Power for the following air motors on the surface ship:

- Two umbilical reels
- Chain winch.

2. SPECIAL FEATURES

- a) The flow control valve, J, is designed to supply a constant air quantity at any space pressure between atmospheric and 60 psig.
- b) The float valve "K" is a safety feature. It will pass air, but will close if filled with water, and therefore prevent flooding of the space in case of a break in the ballast supply main or umbilical.
- c) The two filter/moisture separators (F/M) and the strainer (S) should be dis-assembled and cleaned after approximately every 200 hours of operation. One spare filter should be kept on hand for the surface ship, Dollinger model, filter separator.

3. START UP

- a) Open drain valve "D" and leave it open for about 5 minutes to allow any accumulated water to drain.

CAUTION

Do not forget to shut valve securely, leaving this valve open may result in overpressure in tank.

- b) Drain the moisture separators. When units are empty close drain valves.

- c) Actuate the S.W. cooling system, see Figure 11 and Ref. 4.

- d) Start one air compressor, see Ref. 1. Check that compressor gauge shows approximately 100 psig.

- e) Open valves "A", "C", and "E" and valves "F" in both starboard and port control space. The system is now pressurized and gauges GA-6, "BALL AIR SUP" and GA-7, "BALL AIR STR DISCH" should read about 100 psig.

- f) Start second compressor if required.

4. OPERATION

- a) For operation of sub-systems referenced on the diagram, see the appropriate sections.

- b) To actuate the 50 scfm space supply, open valves "G" and "H". If the air supply is too cold, the temperature may be increased by partially opening valve "B" and, if required, throttling valve "A".

- c) To actuate the breakout system, move the "Valve Directional Control" switch, S-1 to "Open" and the "Breakout Valve Control Switch", S-2 to "On", holding it for about 3 seconds. The solenoid valve shifts, directing pressure to the butterfly valve actuator. The butterfly valve opens and air is supplied to the breakout system. To shut off the air flow, position switch S-1 to "Close" and switch S-2 to "On". Note that the solenoid valve will remain in its position until a new signal is applied, therefore the butterfly valve is kept either open or closed by a positive air pressure.

FIGURE 2

CONSTANT PRESSURE AIR SUPPLY AND OVERPRESSURE PROTECTION SYSTEM

1. DESCRIPTION

Air is provided by two 100 psig, 3 scfm air compressors. The compressors are controlled by pressure switches, which will automatically cycle the units on or off. Normally only the unit with its pressure switch set to start at 105 psi and stop at 120 psi will operate. If the system pressure should drop to 95 psi due to abnormally high air demand, the other unit will start.

The constant pressure air is conveyed through a 5/8" O.D. tube which is part of the multi-tube fluidic umbilical cable.

Constant pressure air is used for the following:

- Supply to the fluidic sensing system.
- Pneumatic valve actuation in both CB control spaces.
- Overpressure protection valve system actuation.
- Direct space supply of emergency life support air.
- Actuation of the surface ship winch and reel control system.

2. SPECIAL FEATURES

- a) The float check valves "K" will allow air to pass, but will close against water flow. If the umbilical or piping outside of the space breaks, the valve in the damaged line will prevent flooding.
- b) The filter/moisture separator (F/M) and the first filter (F) inside of the control space should be dis-assembled and cleaned after approximately every 200 hours of operation. One spare filter element should be kept on hand for surface ship, Dollinger model, filter separator. The filter in the fluidic system branch is described in Ref. 1.

3. START UP

- a) Open drain valve "D" and leave it open for about 5 minutes to allow any accumulated water to drain.

CAUTION

Do not forget to shut valve securely. Leaving this valve open may result in overpressure in tank.

- b) Open drain valves "L" until all water has escaped from compressor air tanks and from the filters. Close valves.

- c) Start compressors, see Ref. 3. Wait until compressor stop at 120 psig tank pressure.

- d) Open valves "A", "B", "C", "E" port and starboard and "M". The constant pressure air system is now operational in both control spaces.

4. OPERATION

- a) For operation of sub-systems referenced on the diagram, see the appropriate sections.

- b) If emergency air supply is required in either control space due to failure of the ballast air supply system, open valve "G".

CAUTION

Opening the direct space supply valve "G" completely will drop the system pressure to a level where the fluidic system and the pneumatic controls become inoperative.

5. OVERPRESSURE PROTECTION VALVES

The purpose of the overpressure protection valve system is to limit the maximum pressure which may be supplied to any ballast or trim tank to a safe level. These limits are defined as the following pressures, above ambient water level, at the top of the tanks:

Pantoon tanks:	20 Feet
Wing tanks :	32 Feet
Hard tanks :	40 Feet

A fluidic transducer is located at the level of each tank top. Each transducer transmits a signal equal to the pressure of the ambient water to pilot valve "H". Valve "H" transmits the same pressure; plus the allowable tank overpressure to the top of the diaphragm of valve "J", tending to open the valve. The air pressure from valve "J" is applied to its bottom of the diaphragm, tending to close the valve. Therefore, the valve discharge pressure will be limited to the sum of the water pressure plus allowable overpressure at each tank top, since if the discharge pressure exceeds this value, it will close the valve.

Gauge GA-9 shows the pilot pressure to the valve in psi, and gauge GA-11 shows the air supply pressure relative to ambient water pressure in feet of water. For the hard tank protection system, these two gauges are duplicated on the surface control console.

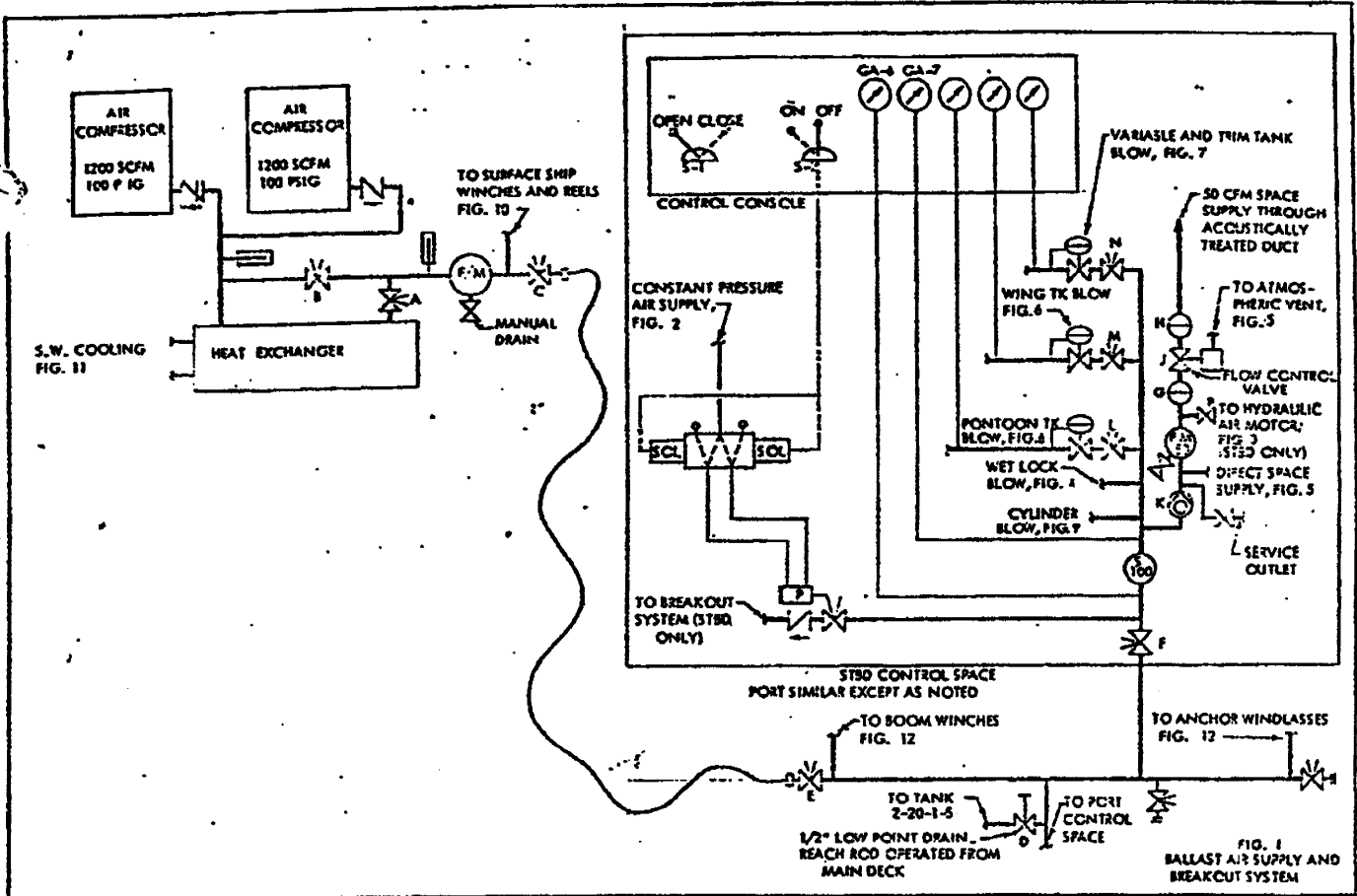

FIG. 1 BALLAST AIR SUPPLY AND BREAKOUT SYSTEM

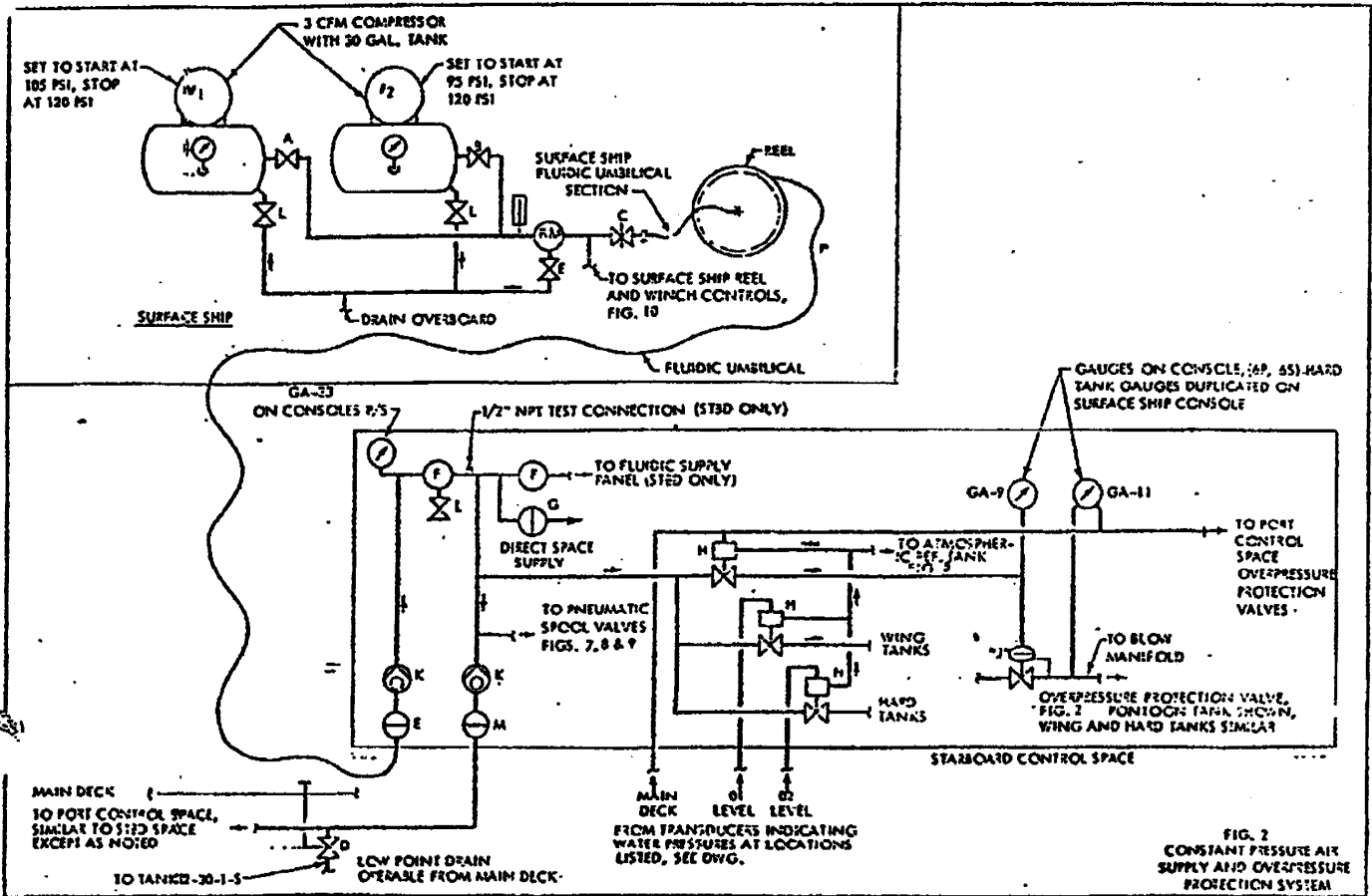

FIG. 2 CONSTANT PRESSURE AIR SUPPLY AND OVERPRESSURE PROTECTION SYSTEM

FIGURES 1 AND 2

Figure 3
HYDRAULIC SYSTEM

1. DESCRIPTION

Hydraulic pressure is used to actuate all remote operated sea valves. The system is pressurized by one electric motor driven pump, see Ref. 6 and one air motor driven pump, see Ref. 7. The pumps have the following capacities and operating characteristics:

- Electric driven: 1.6 gpm at 1800 psi. Pressure switch actuated to start at 1600 psi and stop at 1800 psi.
Air driven: 250 cu. in. per minute at 1000 psi discharge pressure. Capacity decreases with increasing discharge pressure. Stall pressure is 1730 psi.

The air driven pump will maintain a pressure of about 1700 psi on the system. When oil demand is sufficient to drop the pressure to 1600 psi, the electric pump starts and brings the pressure up to 1800 psi. The air pump stops, but will start up again slowly at about 1700 psi. Two 550 cu. in. accumulators reduce cycling and provide reserve oil capacity. Oil pressure is reduced to 1000 psi for the valve actuating system shown on Figs. 6, 7, 8 and 9. The piping distribution system is shown on Figs. 21, 22 and 23.

2. SPECIAL FEATURES

- The hydraulic fluid is Shell "Irus" fluid 905. This is an oil and water emulsion especially designed to reduce fire hazard.
- System cleanliness is of utmost importance. Clean filters and strainers frequently, particularly during the first period of operation.
- Air bleed plugs have been provided in all high points in the system. Crack the plugs occasionally to bleed any accumulated air.

d) Relief valves protect the system against overpressure. They should be checked and adjusted periodically.

a) Several systems use detented hydraulic spool valves as shown on Fig. 7. To insure that the spool will not be moved off the detent by hydraulic shock, a check valve is installed in the return valve from each spool. In addition, the shock effect of the inertia in the long return line from the port control space is reduced by an accumulator precharged to 15 psig.

f) If the hydraulic pressure drops below 1000 psi in the starboard control space, or 900 psi in the port space, an audible and visual alarm will be actuated in the control space and on the WB.

3. START UP

- Open valves "P", Fig. 1 and "A", "B", and "C". Make sure that atmospheric reference tank vent valve is open, see Fig. 5. Supply ballast air to the air driven pump and start the electrically driven pump. Wait until both pumps have stopped. GA-4 will show about 2000 psi and GA-3, std should show about 1000 psi.
- Open valves "D" starboard and "E" port. GA-3, port, should show about 1000 psi.
- System is operational and will continue to operate automatically as long as ballast air and electric power is available.

4. SHUT DOWN

- Close all valves, shut off electric driven pump and air supply to air driven pump.

FIGURE 4
WET LOCK SYSTEM

1. DESCRIPTION

The purpose of the wet lock system is to enable divers to enter and leave the control spaces. The primary consideration of the design is to insure the safety of the divers, the secondary consideration is to prevent flooding of the control space. Normal entrance and exit to the wet lock when the CB is submerged is through the outboard door, which opens directly to the sea. The inboard door opens to the access trunk and is used when the CB is surfaced.

2. SPECIAL FEATURES

- Gauges in the wet lock show the wet lock pressure relative to the ambient water, GA-14, and relative to the control space, GA-18. Gauges in the control space show the space pressure relative to wet lock pressure, GA-1, and relative to surface atmosphere, GA-2.
- Valve "A" is cracked open, so that a small amount of air is discharged all times. The air will exhaust to the sea through valve "B", keeping a wet lock and the ambient water pressure very nearly equal at all times. The water level in the wet lock will be at the level of the inlet to valve "B", 19" below the 02 level. This offers added protection against flooding of the control space.
- When the control space is under hyperbaric pressure, the normal air supply to the space is exhausted through valves "F" and "B". A slight pressure gradient will exist along the control space to the wet lock to the sea flow path.
- The wet lock must be flooded before submerging. This is normally done by leaving wet lock door open until 02 level is submerged, then diver goes over the side and closes door.

a) Valve H is provided to allow diver to vent wet lock air space slowly.

3. OPERATION**a) Entering Atmospheric Control Room**

- Open valve "A" to insure wet lock pressure is equalized with sea pressure.
- Open door to wet lock, enter, close and dog hatch.
- Check gauge "GA-18" to insure control room pressure is atmospheric.
- Undog control room hatch. Check valve "E" closed.

Close valve "A".

- Open valve "H" slowly, when air flow stop open valve "D".
- Open control room hatch, and leave open.

b) Leaving Atmospheric Control Room

- Enter wet lock, close and dog control room hatch, undog wet lock door.
- Close valves "D" and "H".
- Equalize wet lock pressure with sea pressure through valve "A". During pressurization, feel wet lock door with arm or foot to detect when equalization occurs.

CAUTION

The air pressure to valve "A" is 100 psi. Open valve carefully while monitoring gauge GA-19 in order to prevent excessive pressure increase in wet lock.

- Place valve "A" at marked position and open wet lock door.
- Leave wet lock, close and dog door.
- Ascend to surface taking necessary decompression.

c) Entering Hyperbaric Control Room

- Open valve "C" to insure lock pressure equalized with sea pressure.
- Open door to wet lock, enter, close and dog door.
- Check pressure differential, if any, between control room and wet lock by checking gauge GA-18.
- Open valve "H" slowly to give desired decompression rate. When pressures appear equalized, open valve "D".
- Open control room hatch and enter.

d) Leaving Hyperbaric Control Room

- Enter wet lock, close and dog control room hatch.
- Close valves "D" and "H". Open valve "E", undog and open wet lock hatch.
- Close valve "E".
- Check valve "A" open to marked position.
- Leave wet lock, close and dog door, ascend to surface taking necessary decompression.

FIGURE 5
CONTROL SPACE PRESSURIZING, VENTING AND ATMOSPHERIC REFERENCE SYSTEM

1. DESCRIPTION

The control space pressurizing system allows rapid pressurization of the control space. When actuated, using the full flow of both ballast air compressors, the system will increase the space pressure by one atmosphere approximately every 1.7 minutes. The system may be actuated locally or from the WB. The space venting system exhausts the normal air supply to the control space, keeping the space atmospheric. Closing either the manual or the remote operated valve to the tank will cause the space to go hyperbaric if the CB is submerged. The remote operated valve may be operated from the control space console or from the WB.

The atmospheric reference system exhausts miscellaneous instrument vents and the discharge from the air driven hydraulic pump. The tank absorbs surges in air pressure due to starting and stopping of the pump.

2. SPECIAL FEATURES

If the control space is pressurized, most of the electrical circuits serving the CB are automatically cut-out as described in Fig. 13 and Damage Control Item 10.

3. OPERATION

- The normal mode of operation is with the Control space atmospheric. It should only be pressurized in emergencies, such as to prevent flooding. Therefore, except in emergencies, valves "A" and "B" must be open and valve "C" closed.
- To pressurize the control space slowly, position switch S-1 to "Close" locally or on the WB, hold for about 3 seconds. The solenoid operated pneumatic spool valve shifts and valve "A" closes. Space pressure will increase by one atmosphere approximately every 80 minutes. The same result is accomplished by manually closing valve "B".
- To pressurize the space quickly, position switch S-2 to open and hold for 3 seconds. The spool valve shifts and valve "C" opens.

CAUTION

When pressurizing a control space rapidly, space overpressure may result unless the space pressure is monitored closely and the air supply is shut off when the space pressure reaches or slightly exceeds ambient water pressure.

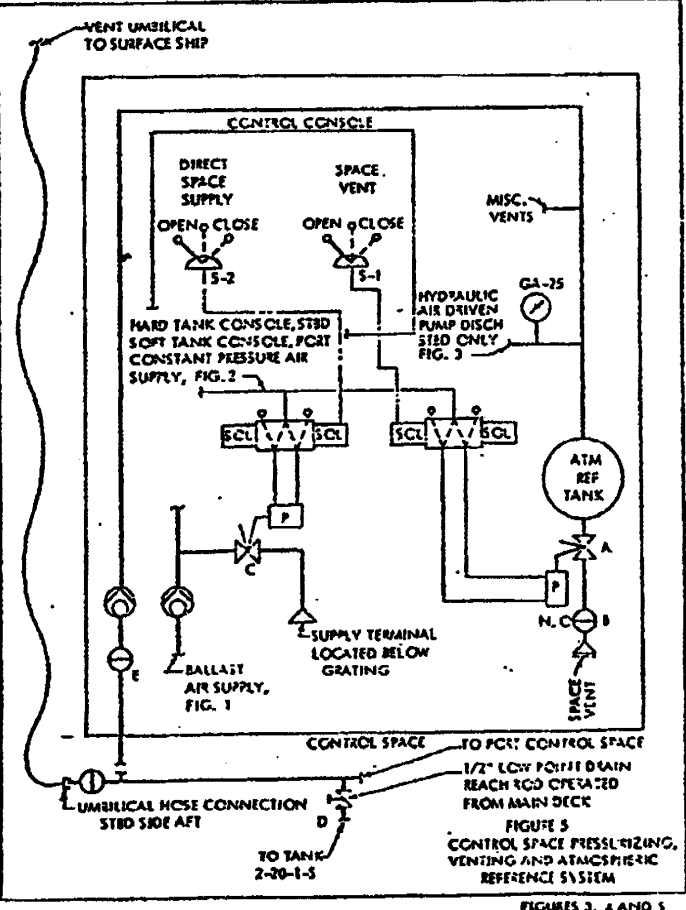
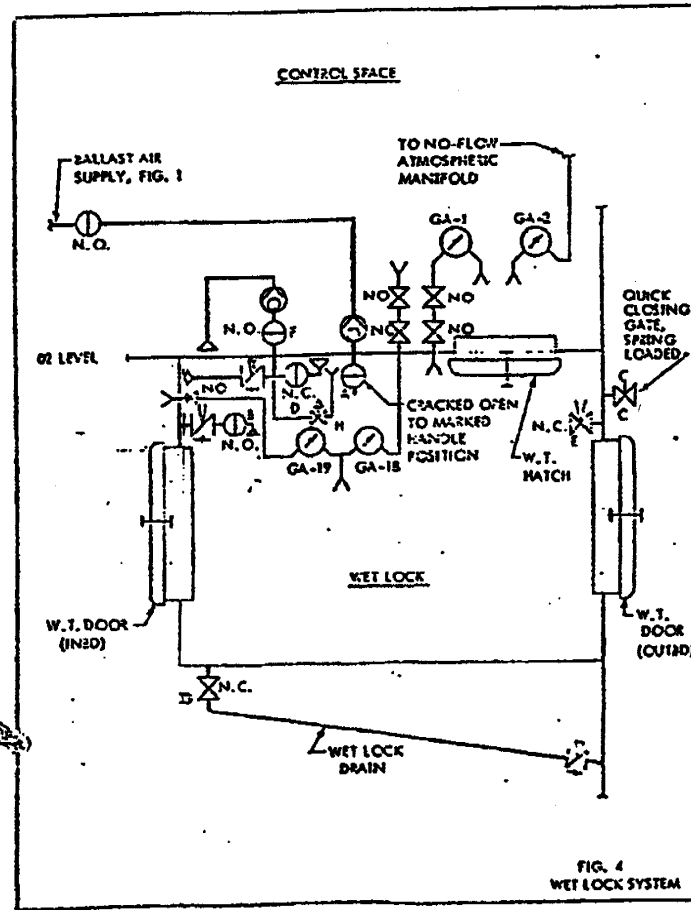
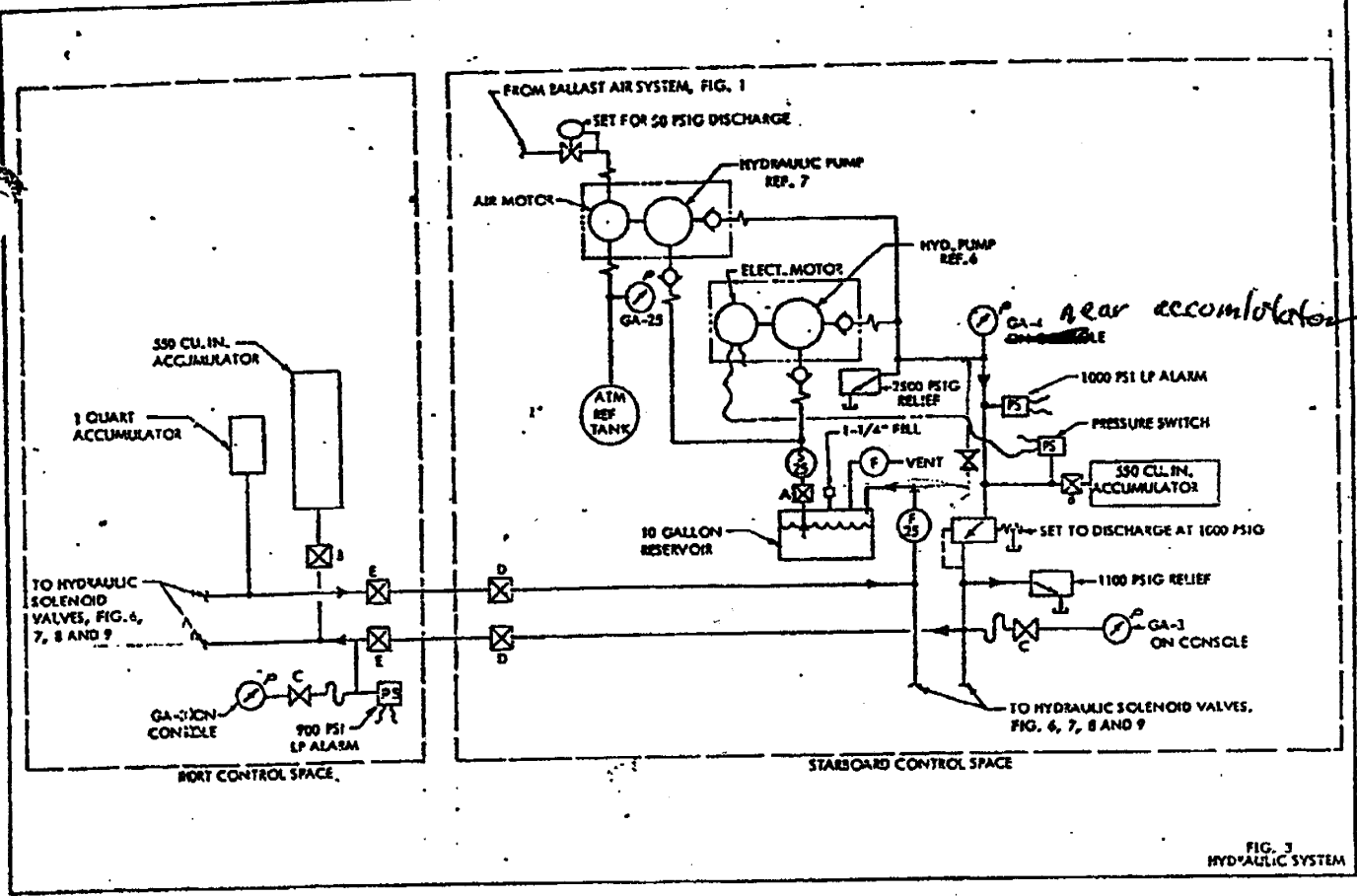

FIGURES 3, 4 AND 5

FIGURE 6
SOFT TANK FLOODING AND BLOWING

1. DESCRIPTION

When flooding soft tanks (wing, pontoon or rake), water enters the tank through the sea chest, a hydraulically operated sea valve and a length of pipe. The air in the tank is expelled through a vent pipe to either the starboard or port control space, through a 3 way ball valve and overboard through a check valve and butterfly valve.

When blowing tanks, air is supplied from the ballast air system, Fig. 1, through the overpressure protection valves, Fig. 2, and through a blow manifold to the tanks. Water is expelled through the sea valve. The piping distribution system is shown on Figures 15 and 16.

2. SPECIAL FEATURES

- The vent pipe terminals in the pontoon tanks are kept as close to the over head as possible to prevent trapped air bubbles when flooding tanks.
- A float check valve, "A", is located in the lowest point in each pontoon tank vent line. The valve will open and drain water from the pipe when the tank is being blown, but will close during flooding when the water level reaches the level of the ball float. This insures that the tank will fill almost completely, providing the float valve does not leak. These valves must be checked regularly to insure that they will seat tightly. After the vent pipe has been filled with water, no additional venting can occur unless the water level is first lowered to below the float check, 6 feet below the main deck.
- Should the float check valve fail to close, trapped air may be vented from a pontoon tank through a flush pipe plug located directly over each vent line terminal.
- Should a sea valve become inoperative, the water in the tank may be expelled to an adjacent tank through an emergency blow valve operable from the main deck. These valves are shown on Figure 20.

3. OPERATION, FLOODING

- Air, hydraulic, pneumatic, fluidic and electrical systems must be operational.
- Open valve "B", port and starboard, and all valves "C".
- Position valve "D" to "Vent".
- Pressurize blow manifold, Fig. 1, and perform operation 4(a), (b) and (c).
- Position valve "E" to "open". Hydraulic oil will shift the piston operated actuator and open valve "F", beginning flooding.
- Flooding is complete when the sound of air rushing through the vent pipes cease, and/or when the CB draft stops increasing. When flooding is complete, position sea and vent valves as specified in Section IV-B.

CAUTION

To prevent tank overpressure due to leaks or misoperation, leave either valve "D" in the vent position or valve "F" open whenever possible, with valves "B" and "C" open.

4. OPERATION, BLOWING

- Check that the overpressure protection valves are operating properly, see Fig. 2.
- Open all valves "C".
- Position valve "E" to open. Hydraulic oil will shift the piston operated actuator and open valve "F".
- Position valve "D" to "blow". Compressed air will enter the tank and force the water out through the sea valve.
- Completion of blowing will be indicated by a sudden pressure drop in the ballast air supply main and by emergence of air bubbles outboard of the vessel in way of tank being blown.
- After blowing is complete, close the sea valve "F" and immediately position valve "D" to "vent."

CAUTION

Always open the sea valve "F" before opening the blow valve "D" in order to insure that tank overpressure will not occur.

FIGURE 7
VARIABLE TANK FLOODING AND BLOWING

1. DESCRIPTION

Flooding and blowing of variable tanks may be controlled from either the starboard control space or from the WB. The operational steps are identical in either case.

When flooding, water enters into a recess in the inboard wing wall, through a hydraulically operated sea valve, a pipe and to the tank. The air in the tank is expelled through a vent pipe and a pneumatically operated butterfly valve to a vent manifold and overboard through a check valve and a butterfly valve.

When blowing tanks, air is supplied from the ballast air system, Fig. 1, through the overpressure protection valve, Fig. 2 and to the tank. Water is expelled through the sea valve.

The piping distribution system is shown on Figure 17. The entire electrical/pneumatic/hydraulic control and indication system is shown on Drawing No. 7043-21.

2. SPECIAL FEATURES

- A removable baffle plate is located in front of the sea valve in order to deflect the water when blowing tanks.
- Each tank has a drainwell located in its lowest point. The well is covered by 1/2" mesh galvanized screen. The well must be kept clean and the screen should be inspected regularly and replaced if it has become damaged.
- Special indicating instrumentation has been provided for four variable tanks. They are: 01-12-18, 01-12-23, 01-36-18 and 01-36-23. The intention is that these valves will be used during the final descent or initial ascent operation. The instrumentation consists of:

An interlock which prevents opening the blow valve unless the vent valve is closed and prevents opening the vent valve unless the blow valve is closed.

Lamps on the starboard control space hard tank console and on the surface ship control console, indicating whether vent, blow and sea valves are open or closed.

Gauges on the starboard control space hard tank console and on the surface ship control console, indicating tank water level and internal tank pressure in excess of external pressure near the tank top.

3. OPERATION, FLOODING

- Air, hydraulic, pneumatic, fluidic and electrical systems must be operational.
- The electrical control location selection switch shall initially be positioned to "Local". See Fig. 13.
- Open valve "A" port and starboard, and all valves "B".
- Position valve directional control switch, S-1 to "Open".
- Position the vent valve operating switch, S-2 to "On", hold for 3 seconds. The solenoid operated pneumatic valve "C" shifts and directs air to the butterfly valve "D" operator, which opens the valve.
- Position the sea valve operating switch, S-3 to "On", hold for 3 seconds. The solenoid operated hydraulic valve "E" shifts and directs oil to the butterfly valve "F" operator, opening the valve and flooding begins.
- Flooding is complete when the sound of air rushing through the vent pipes cease, and/or the CB draft stops increasing. For the 4 instrumented tanks, the water level gauges will indicate when the tank is full. When flooding is complete, position valves D and F as directed in Section IV-B.

CAUTION

To prevent tank overpressure due to leaks or misoperation, leave either valve "D" or "F" open whenever possible.

4. OPERATION, BLOWING

- Check that the overpressure protection valves "H" are operating properly, see Fig. 2.
- Check that the vent valve is closed.
- Position switch S-1 to "Open".
- Position switches S-3 and S-4 to "On" in that order. Sea valve "F" and blow valve "G" will open. Ballast air flows through valves "H", "G" and "B" to the tank, dispelling water through valve "F".
- Completion of blowing is indicated by a sudden pressure drop in the ballast air supply main and by emergence of air bubbles along the inside of the wing wall in way of tank being blown. For instrumented tanks, the water level indicator will show when the tank is empty.
- After blowing is complete, position S-1 to "Close" and S-4 to "On", closing valve "G".

CAUTION

Leave sea valve "F" open whenever possible in order to prevent overpressurization of tank due to air leaks or misoperation.

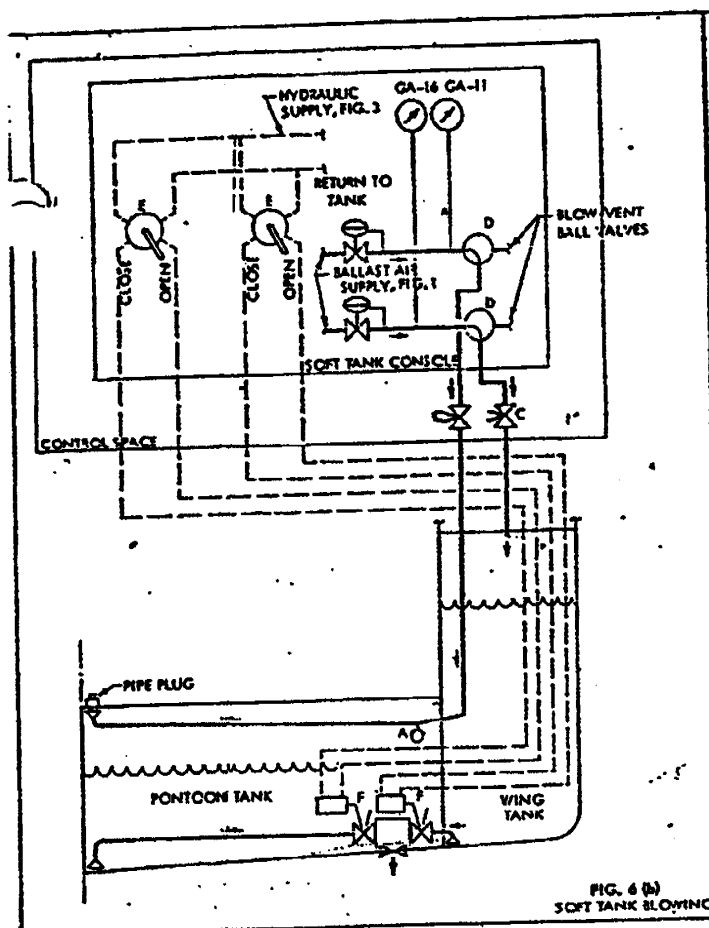

FIG. 6 (b) SOFT TANK BLOWING

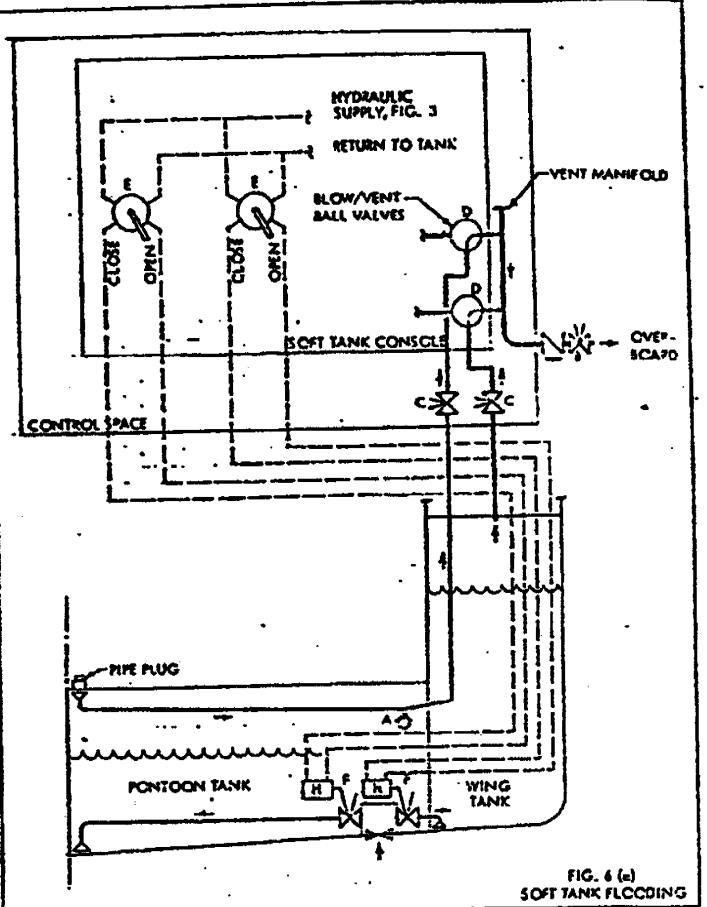

FIG. 6 (a) SOFT TANK FLOODING

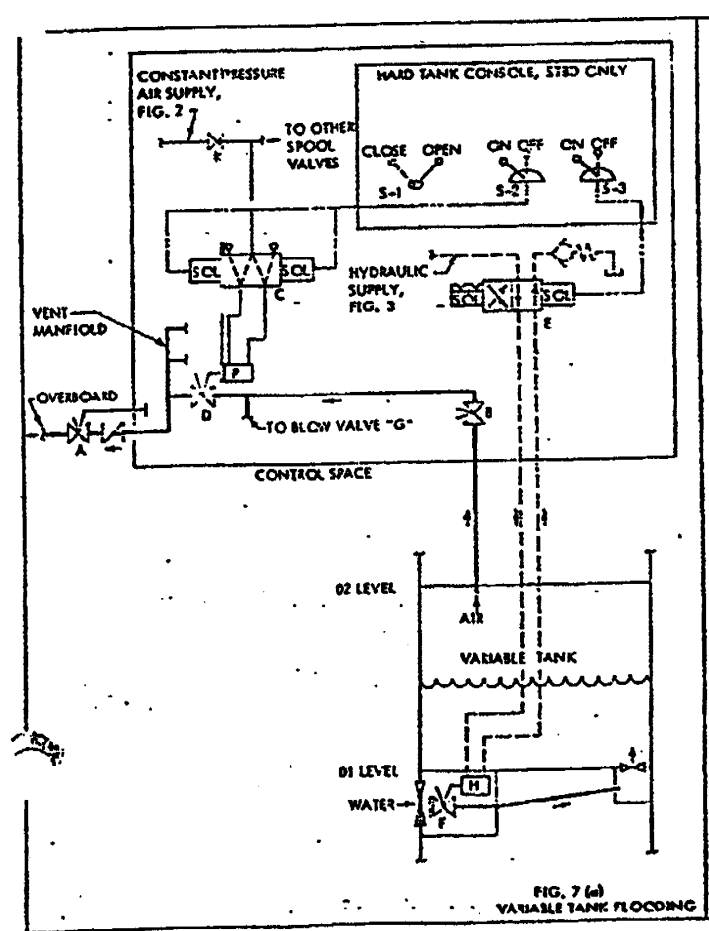

FIG. 7 (a) VARIABLE TANK FLOODING

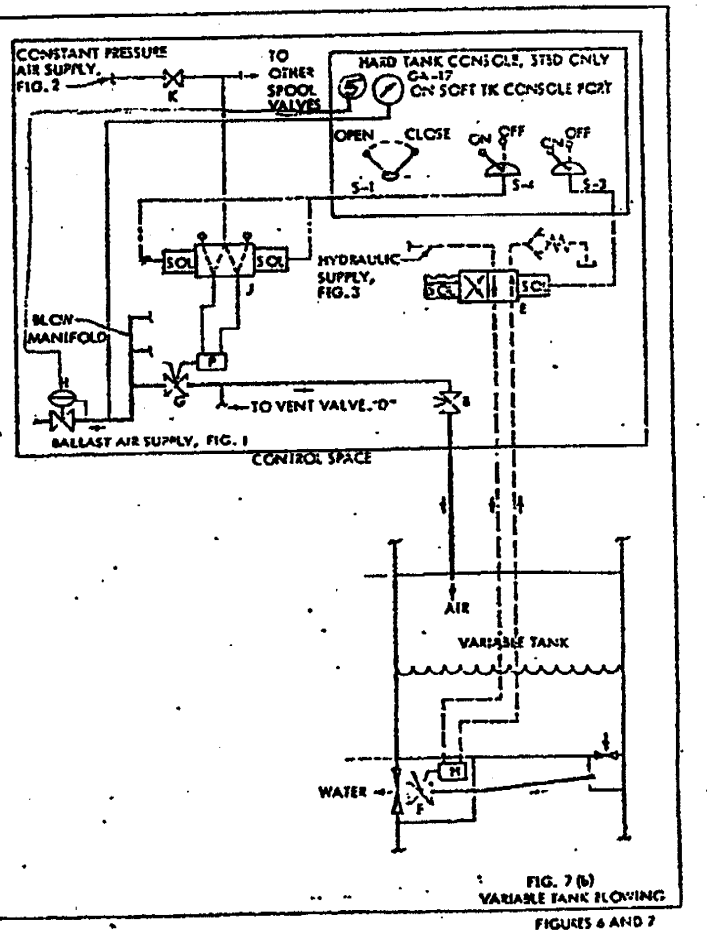

FIG. 7 (b) VARIABLE TANK FLOWING

FIGURE 10
WB REEL AND WINCH POWER AND CONTROL

1. DESCRIPTION

Umbilical handling equipment consists of the identical electrical and fluidic umbilical cable reels, and the chain winch. Each unit is powered by a reversible air motor and is equipped with a pneumatically actuated brake. Motors and brakes are controlled from a single common console with one lever controlling each unit. Brakes are set automatically in the lever "stop" position. Gauges display air pressure to motor and brake.

The system works as follows: Air for powering the motors is supplied from the ballast air system. The air passes through one ahead and one astern relay valve "A" and to the ahead and astern ports on the motors. Each relay valve is actuated by a control signal and the flow through the valve is proportional to the control pressure. Valve "B" controls the chain winch motor exhaust by opening one valve "G", and closing the other. Valve "C" exhausts the reel motors. The control signal is determined by the control lever angle. The levers also actuate the brakes. The release point of the brakes is set by regulator "D". The regulator applies a pre-determined, fixed, pressure to one side of the pilot of valve "E". When the control signal exceeds this pressure, valve "E" shifts and the brake is released. The pilot should be adjusted to give smooth operation without slippage when the brake releases.

2. SPECIAL FEATURES

The reel brakes are fail safe, they will engage automatically through springs if air supply is interrupted. The chain winch brake is double

acting and will not engage on air supply failure. This brake is backed up by a manual engagement feature and a mechanical chain stopper. Should the constant pressure air fail, an alarm will sound before the pressure drops to a level which will cause the brake to slip.

CAUTION

If the low constant pressure air alarm sounds, immediately engage brakes on all three units, then quickly set the manual brake on the chain winch.

3. OPERATION

Keep the control lever straight up when no reel or winch motion is desired. All gauges read zero except chain winch "brake on" gauge which reads 100 psi. To reel in or out move the lever as indicated by arrows on control head. When brakes disengage, "brake off" gauges go to 100 psi readings, "brake on" gauge goes to zero.

CAUTION

Umbilical reels must not be operated when surface sections of the umbilicals are attached to reels. To prevent reel operation close valves "F".

FIGURE 11
SEA WATER COOLING SYSTEM

1. DESCRIPTION

The sea water system cools the ballast air through a water to air heat exchanger. Water is supplied through a overboard hose equipped with a foot valve in the free end. It passes through the pump, the heat exchanger and back overboard.

The pump capacity is 50 gpm at 50 feet TDH. The heat exchanger is

designed to reduce the ballast air temperature from 250°F to 110°F with 85° incoming water.

2. OPERATION

Connect overboard hoses. Close heat exchanger discharge valve "A". Remove plug at priming connection and fill system completely with water, replace plug. Start pump and when discharge gauge shows pressure, open valve "A".

FIGURE 12
CB WINCHES, POWER AND CONTROLS

1. DESCRIPTION

The CB cargo and anchor handling system consists of two booms aft, each having two vang winches, one topping winch and one hoisting winch. The two anchor windlasses are located on the forecastle deck forward. Each unit is powered by an air powered motor supplied from the ballast air system.

These units will be submerged with the CB. It is extremely important that water does not penetrate into the motors during submergence, therefore all possible points of leakage, such as shaft seals, must be kept in first class condition and serviced according to the manufacturers recommendations.

2. SPECIAL FEATURES

The forward and the aft set of air motors are each supplied through a filter. Since the ballast air is already thoroughly filtered, these will rarely need cleaning, but should be inspected occasionally.

3. OPERATION

Before operating any air motor, open valves "B".

The anchor windlasses are operated by the 4 way ball valve "A", which diverts air to either the ahead or the astern port in the windlass motor. Valve "C" must be open if the windlass is being driven by the anchor weight. In this case, the motor becomes a compressor and valve "C" vents the air.

All boom winches are controlled through levers, "D". The hoist and topping winch brakes are set automatically when the lever is in the neutral position.

CAUTION

Before diving, all valves "B" must be closed. Failure to do so will cause equipment damage.

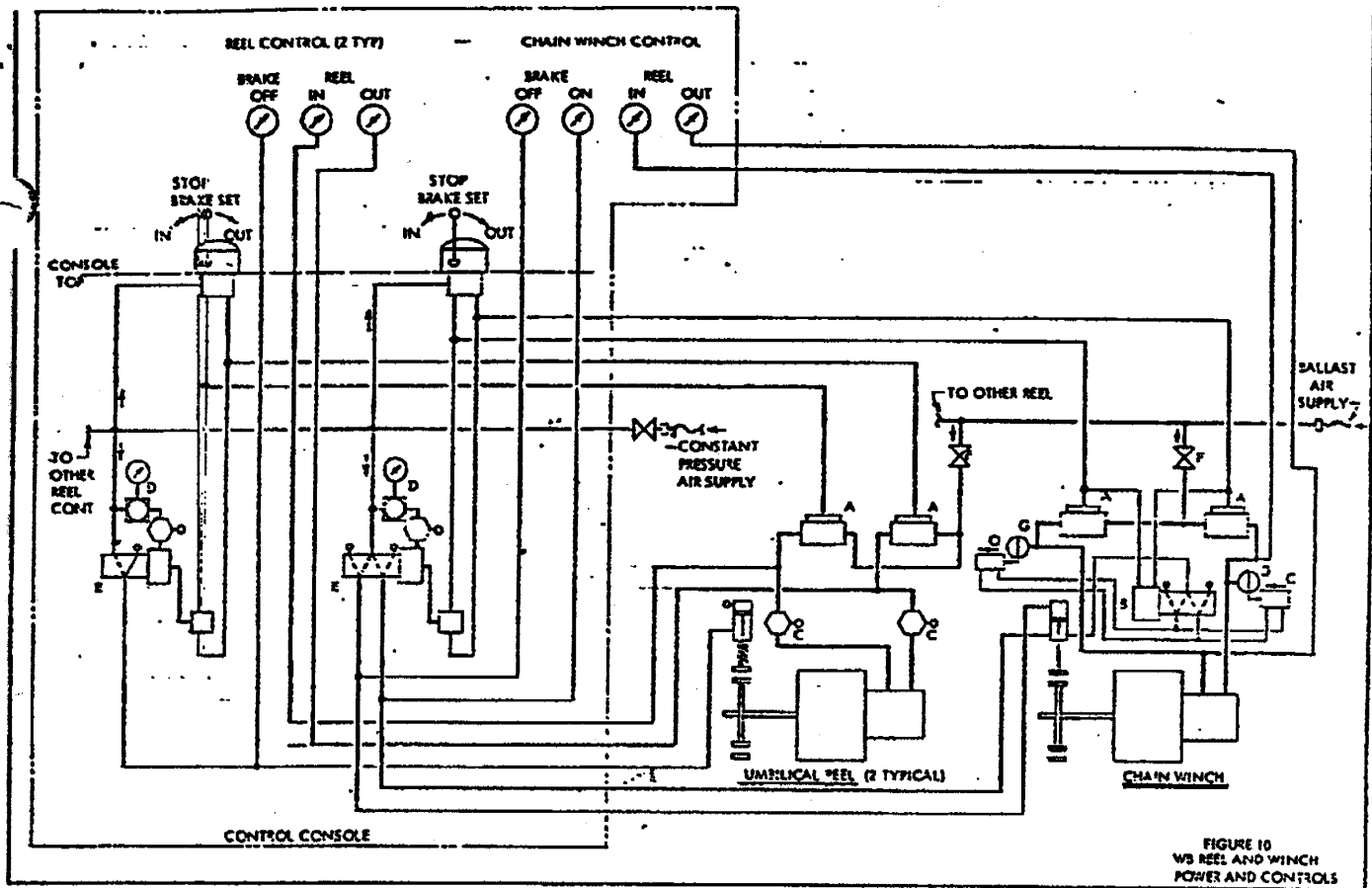

FIGURE 10
WB REEL AND WINCH
POWER AND CONTROLS

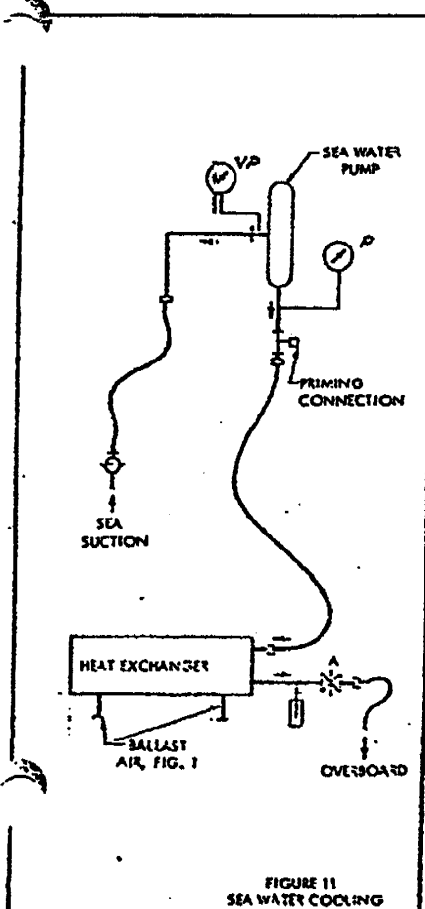

FIGURE 11
SEA WATER COOLING

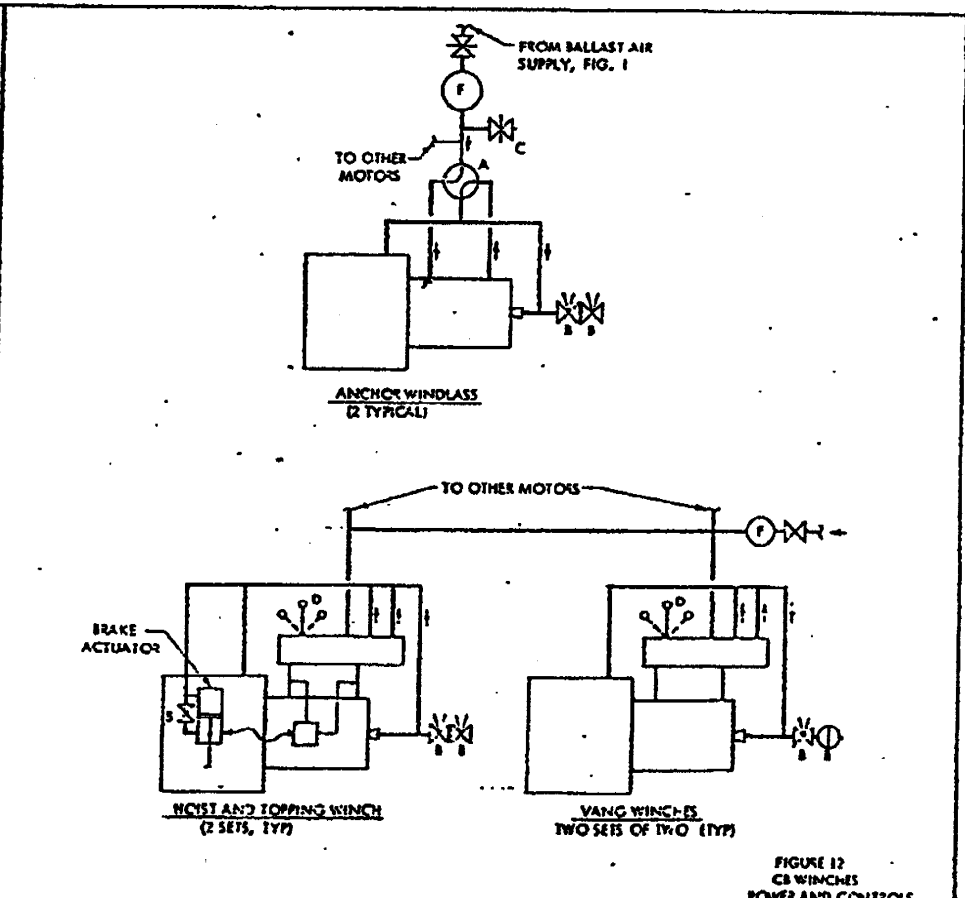

FIGURE 12
CB WINCHES
POWER AND CONTROLS

FIGURE 13 ELECTRICAL SYSTEM

1. DESCRIPTION

Electrical power may be supplied from the remote electrical system on the surface ship via the electrical umbilical, or from shore power via a shore power connection in the starboard control space.

The remote electrical system is shown in detail on Drawing No. 7043-53, and is described as follows:

- Either of two 460V, 3Ø, 10 KW self-regulated diesel generator units may be used to generate the electrical power.
- A 460V Distribution Panel provides circuit selection and protection for the 460V circuit. This panel contains mechanically interlocked circuit breakers for selection of generators.
- A 460/120V transformer panel provides both 460V-3Ø power and 120V-1Ø control power to the remote control console.
- The electrical umbilical transmits the electrical power and control signals from the remote control console to the starboard control space on the CB.

The electrical umbilical is shown in detail on Drawing No. 7043-56, and contains the following types of conductors:

FUNCTION	SIZE, AWG	QUANTITY
460V/3Ø electrical power	#8	3
120V/1Ø control power	#12	3(1 spare)
Valve control, indicator lamps, alarms, call bell	#16	197
Sound powered telephones	#16 - Shielded	2 pairs

The CB Power and Lighting system is shown in detail on Drawing No. 7043-25, and is described as follows:

- A 440V/3Ø power panel in the starboard control space provides circuit selection and protection for the 440V power circuits in the CB. This panel also has mechanically interlocked switches for selection of either umbilical power or shore power.
- 440/120V transformers in both port and starboard control space provide conversion to 120V, 3Ø power.
- 120V lighting panels in both port and starboard control space provide 120V, 1Ø circuit selection and protection.

The Valve Control and Indication Circuit is shown in detail on Drawing No. 7043-21, sheets 1-3. This circuit contains a Control Power Local-Remote Switch located on the Hard Tank Console to provide selection as follows:

- LOCAL position** - permits control of pneumatic and hydraulically actuated valves from the Hard Tank Console using electrical control power from the Power and Lighting system.
- REMOTE position** - permits control of pneumatic and hydraulically actuated valves from the surface ship Remote Control Console using electrical control power from the Remote Control Console via the electrical umbilical.

The valve control circuit provides three types of valve control, as follows:

- Variable Tank Valves** - One ON-OFF switch for each valve to be used in conjunction with a common Valve Directional Control OPEN-CLOSE switch.
- Stabilizing Cylinder Valves** - One valve directional control OPEN-OFF-CLOSE switch for each valve.
- Trim Tank Valves** - One BLOW-OFF-FILL switch for each trim tank.

2. SPECIAL FEATURES

The 10 KW diesel generators are self-regulated and do not require external adjustments to maintain correct voltage and frequency. The remote electrical system will automatically disconnect all but essential power to the CB in the event that either control space pressure exceeds 10 psig. (See Drawing No. 7043-53.)

3. PRECAUTIONS

- a) Do not attempt to operate both generators in parallel (interlock normally would prevent this).
- b) Do not attempt to start more than one motor at a time. Allow 30 seconds between starts for the generator to stabilize.
- c) Except in an emergency, do not operate more than two valves simultaneously. (This restriction does not apply to the trim system.)
- d) Prior to leaving the starboard control space during a dive, always place the Control Power Switch to REMOTE.

4. REMOTE POWER & LIGHTING SYSTEM OPERATION

- a) Place all 460V Distribution Panel circuit breakers to OFF.
- b) Start and warm up selected generator, following manufacturer's instructions, Re. 4.
- c) Place selected generator circuit breaker to ON.
- d) Press generator overload relay START switch.
- e) Energize compressor/generator station lights and equipment as desired by placing appropriate circuit breaker to ON.

CAUTION

- Wait 30 seconds between consecutive motor starts.
- f) Check that the CB Electrical Power Switch is OFF (located in Remote Control Station).

- g) Energize Remote Control Station Power and Lights by placing appropriate circuit breaker on 460V Distribution Panel to ON.
 - h) When the electrical umbilical is connected and the CB Starboard-Control Station asks for power, place the CB Electrical Power switch to ON.
- The Remote Control Console and the CB will be energized at this point.

5. CB POWER AND LIGHTING SYSTEM OPERATION

- a) Place all circuit breakers on the 440V Power Panel and 120 V Lighting Panels to OFF.
- b) If power is to be taken from shore power, connect shore power and place Power Transfer switch to SHORE PWR.
- c) If power is to be taken from the surface ship, place Power Transfer Switch to SURFACE SHIP and ask the Remote Control Station for electrical power.
- d) When the 440V Power Panel is energized, energize either or both 120V Lighting Panels and the hydraulic pump by placing the appropriate 440V circuit breakers to ON.
- e) Energize the 120V circuits by placing the appropriate 120V circuit breakers to ON.

6. LOCAL VALVE CONTROL

- a) Energize the 120V console power circuit and relay power circuit as described in paragraph 5 above.
- b) Place the Control Power Switch to LOCAL.
- c) Operate remotely-actuated valves using valve control switches on Hard Tank Console as described in Paragraph 8 below.

7. REMOTE VALVE CONTROL

- a) Place Control Power Switch to REMOTE.
- b) Operate remotely-actuated valves using valve control switches on Remote Control Console as described in paragraph 8 below.

8. VALVE CONTROL - GENERAL

VALVE	SWITCH	OPERATION
All variable tank valves Breakout air valve	Common valve directional control switch Individual valve ON-OFF switch	Place to OPEN or CLOSE, as desired. Hold to ON for 3 seconds then release to spring centered OFF position.
Stabilizing cylinder valves, space supply valves, space vent valves	Individual valve OPEN-CLOSE switch	Hold to desired position for 3 seconds, then release to spring centered position.
Trim tank valves	Individual trim tank BLOW-OFF-FILL switch	Place receiving tank switch to FILL. Place sending tank switch to BLOW. When trim transfer is complete, place both switches to center OFF position.

9. GROUND TEST (ALL LOCATIONS)

Place Ground Test Switch to TEST position. If any ground test lamp darkens, the corresponding phase has a ground which should be cleared.

10. ALARMS

- a) An alarm condition will be indicated by both an audible horn and an indicator lamp.
 - b) The horn may be silenced by placing the Alarm Silence Switch to OFF.
 - c) Once the alarm condition has been corrected, place the Alarm Silence Switch to ON.
- A list of alarms is included in the front of the damage control section.

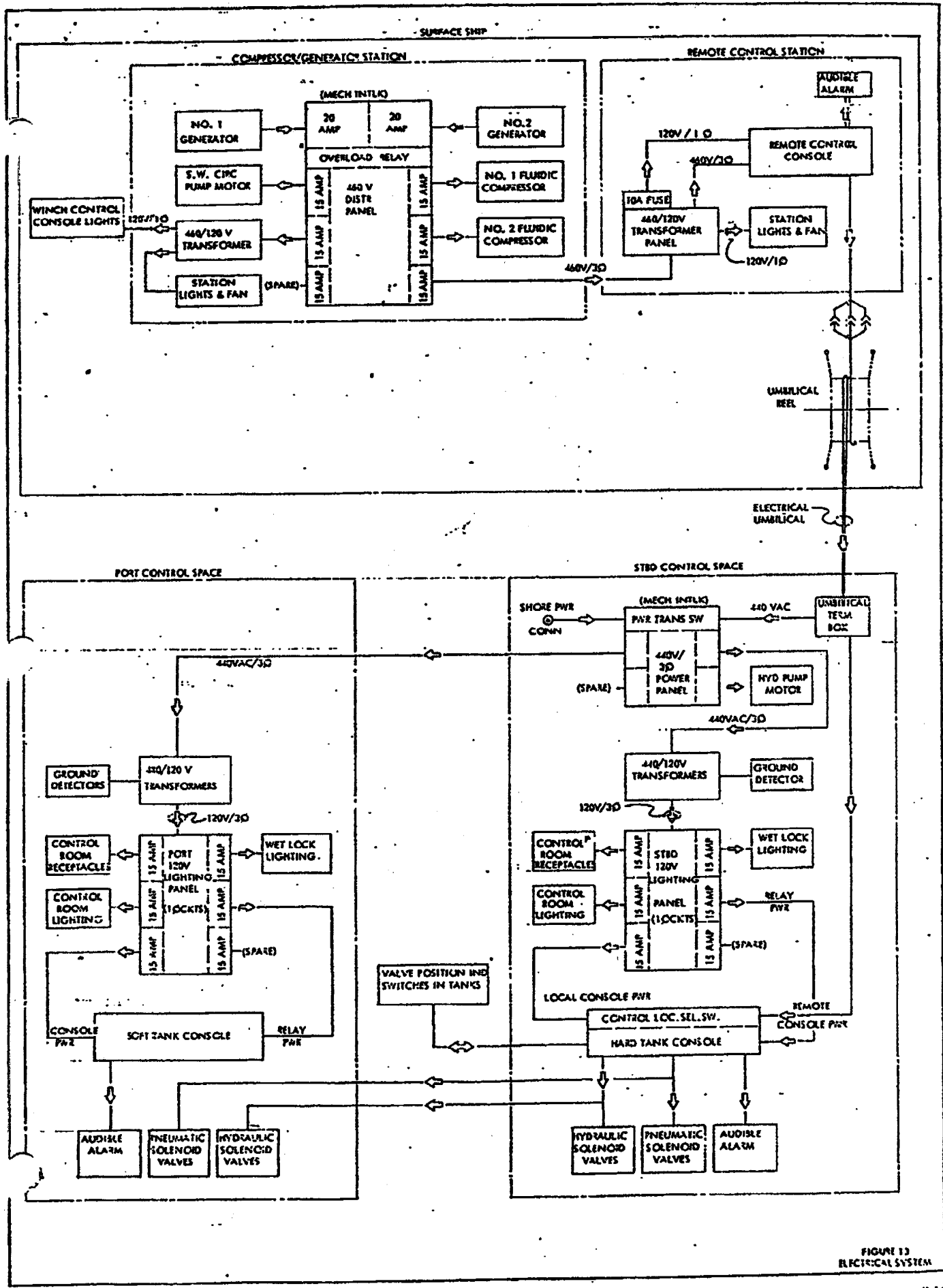

FIGURE 13 ELECTRICAL SYSTEM

C. INTRODUCTION TO FOLDOUTS

Figures 14 through 27 show pipe runs throughout the vessel isometrically. There are intended to help the operator in becoming familiar with the entire piping installation. Figures 1 through 13 were simplified as much as possible in order to illustrate operational features. Figures 14 through 27 show the extensive systems required to convert the initial operation to the desired effect on the vessel. The operator is urged to study both groups of figures until he is familiar with the relationships between them.

Explanatory notes and references to related figures are added to each sheet when required.

<u>FIGURE</u>	<u>TITLE</u>
14	4" Ballast Air, 2" vent, and anchor air supply
15	Pontoon and rake tanks, flood-blow-vent
16	Wing tanks, flood-blow-vent
17	Variable tank, flood-blow-vent
18	Trim tank - vent, blow and transfer system
19	Stabilizing cylinders, flood, blow and vent
20	Emergency drain - rake, wing and pontoon tanks
21	Hydraulic lines and valves for pontoon, wing and rake tanks
22	Hydraulic lines and valves for variable and trim tanks
23	Stabilizing cylinder hydraulic lines and valves
24	Fluidics
25	Bottom breakout system
26	Sounding tube locations
27	Fire main

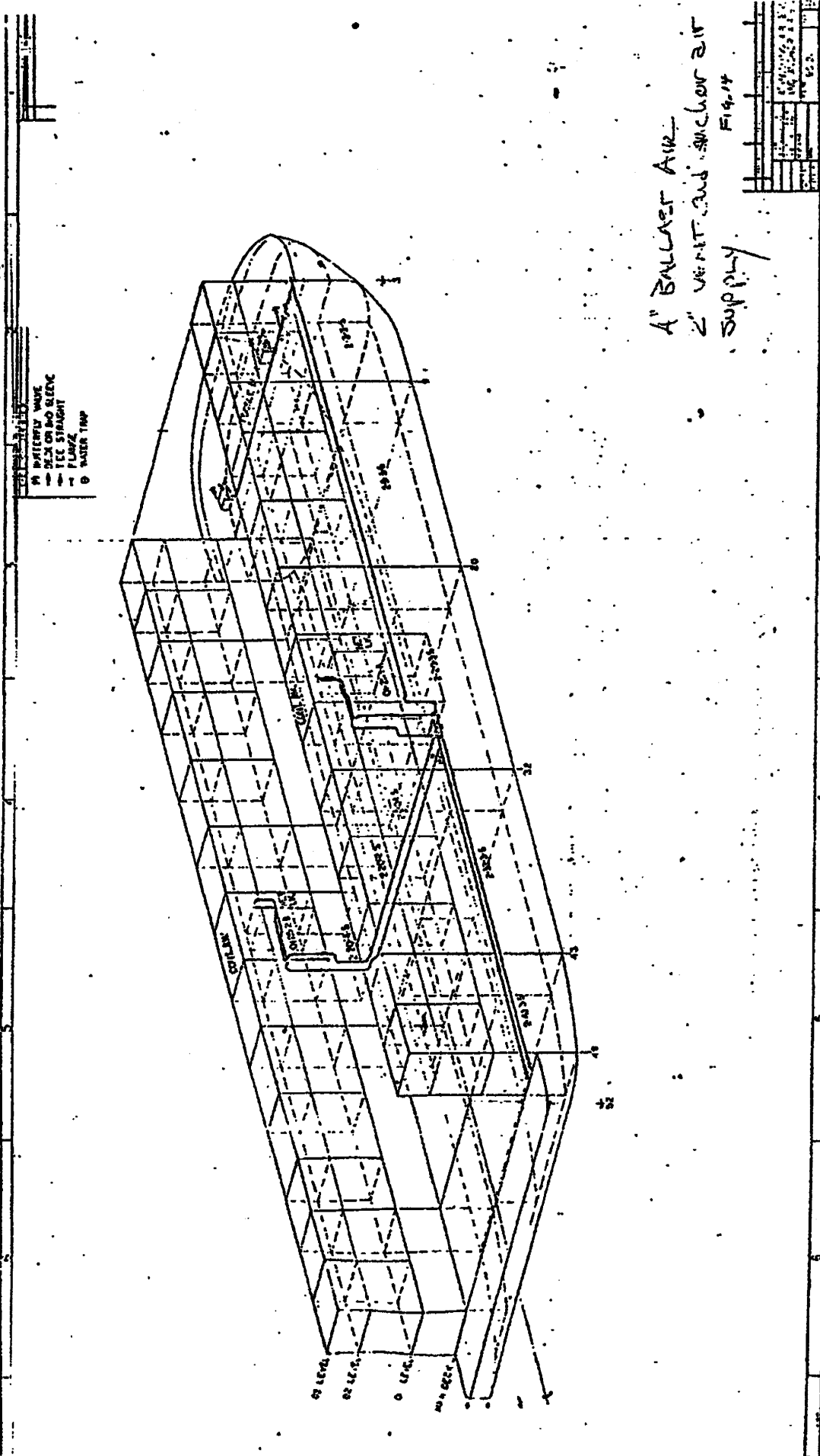

W WATER TIGHT WORK
 D DICK OR BOW BLEND
 T TEE STRAIGHT
 F FLANGE
 W WATER TIGHT

1" BALLAST AIR
 2" VENT AND ANCHOR AIR
 SUPPLY
 FIG. 14

NO.	REV.	DATE	BY	CHKD.

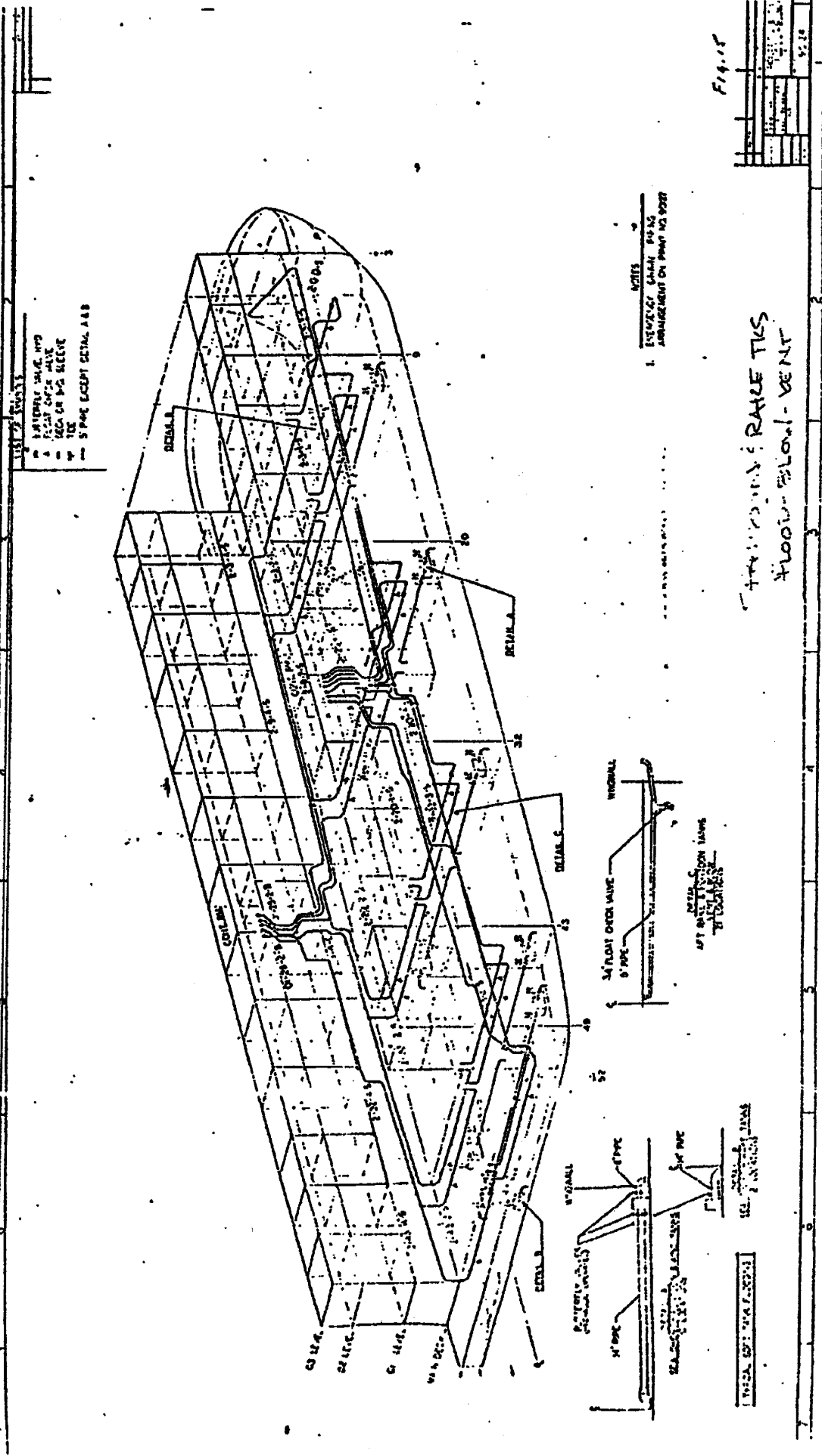

1. 1/2" DIA. STEEL PIPE
 2. 1/4" DIA. STEEL PIPE
 3. 1/2" DIA. STEEL PIPE
 4. 1/4" DIA. STEEL PIPE
 5. 1/2" DIA. STEEL PIPE EXCEPT DETAIL A & B

1. 1/2" DIA. STEEL PIPE
 2. 1/4" DIA. STEEL PIPE
 3. 1/2" DIA. STEEL PIPE EXCEPT DETAIL A & B

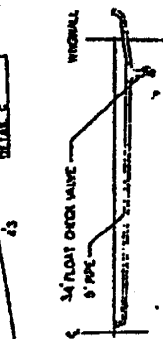

1. 1/2" DIA. STEEL PIPE
 2. 1/4" DIA. STEEL PIPE
 3. 1/2" DIA. STEEL PIPE EXCEPT DETAIL A & B

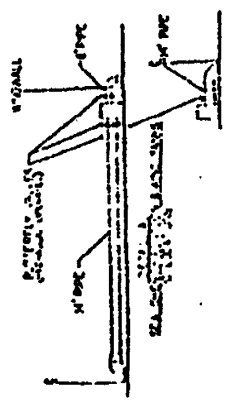

1. 1/2" DIA. STEEL PIPE
 2. 1/4" DIA. STEEL PIPE
 3. 1/2" DIA. STEEL PIPE EXCEPT DETAIL A & B

Fig. 11

THE SHIP'S RAISE TKS
 FLOODING BELOW-VENT

NO.	REV.	DATE	BY	CHKD.
1				
2				
3				
4				
5				
6				
7				
8				
9				
10				
11				
12				
13				
14				
15				
16				
17				
18				
19				
20				
21				
22				
23				
24				
25				
26				
27				
28				
29				
30				
31				
32				
33				
34				
35				
36				
37				
38				
39				
40				
41				
42				
43				
44				
45				
46				
47				
48				
49				
50				
51				
52				
53				
54				
55				
56				
57				
58				
59				
60				
61				
62				
63				
64				
65				
66				
67				
68				
69				
70				
71				
72				
73				
74				
75				
76				
77				
78				
79				
80				
81				
82				
83				
84				
85				
86				
87				
88				
89				
90				
91				
92				
93				
94				
95				
96				
97				
98				
99				
100				

LEGEND
 BATTERY WARE, AND
 DECK OR BOW WARE
 DECK
 TYPE COFFIN DETAIL A

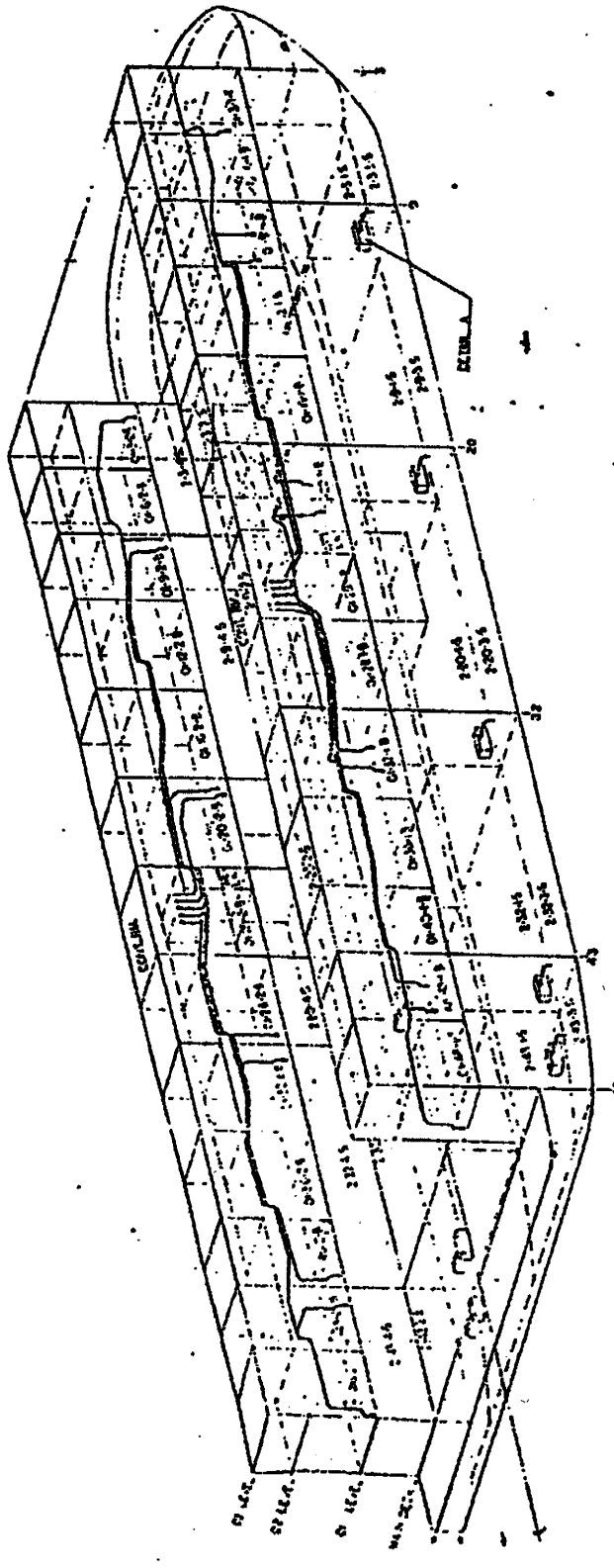

TO REINFORCE
 WING TRUSS
 FLOOD-BLOW-VENT

Fig. 16

NO.	DESCRIPTION	DATE
1	AS SHOWN	
2		
3		
4		
5		
6		
7		
8		
9		
10		

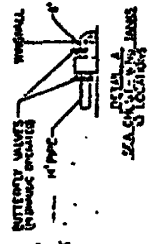

DECK LOCATION

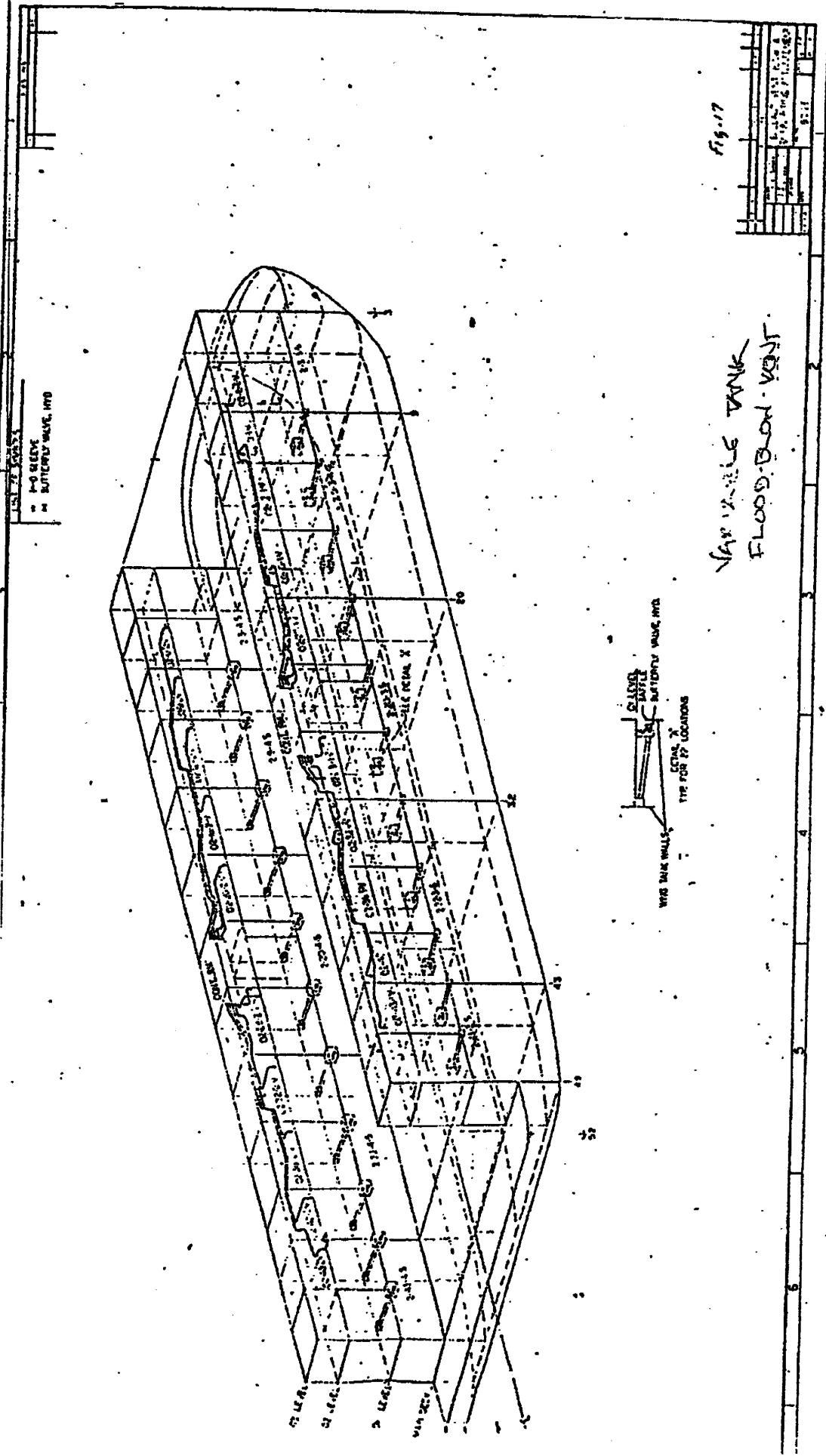

VAR. TANK FLOOD-BLOW VENT

Fig-17

WIND TANK WALLS
GLASS
WALL
BATTERY WAVE, INTD
LECTS X
THE FOR P LOCATIONS

P-O BLEVE
BATTERY WAVE, INTD

NO.	REV.	DATE	BY
1			
2			
3			
4			
5			
6			
7			
8			
9			
10			

- AS BATTERY WATER
- AS W/PIPS EXPOSED W/ST
- CLC ON B/W ALICE
- TEC. STIMANT
- FLANGE
- 1" PIPE - TRANSFER SYSTEM
- 3" PIPE - BLOW AND TEST

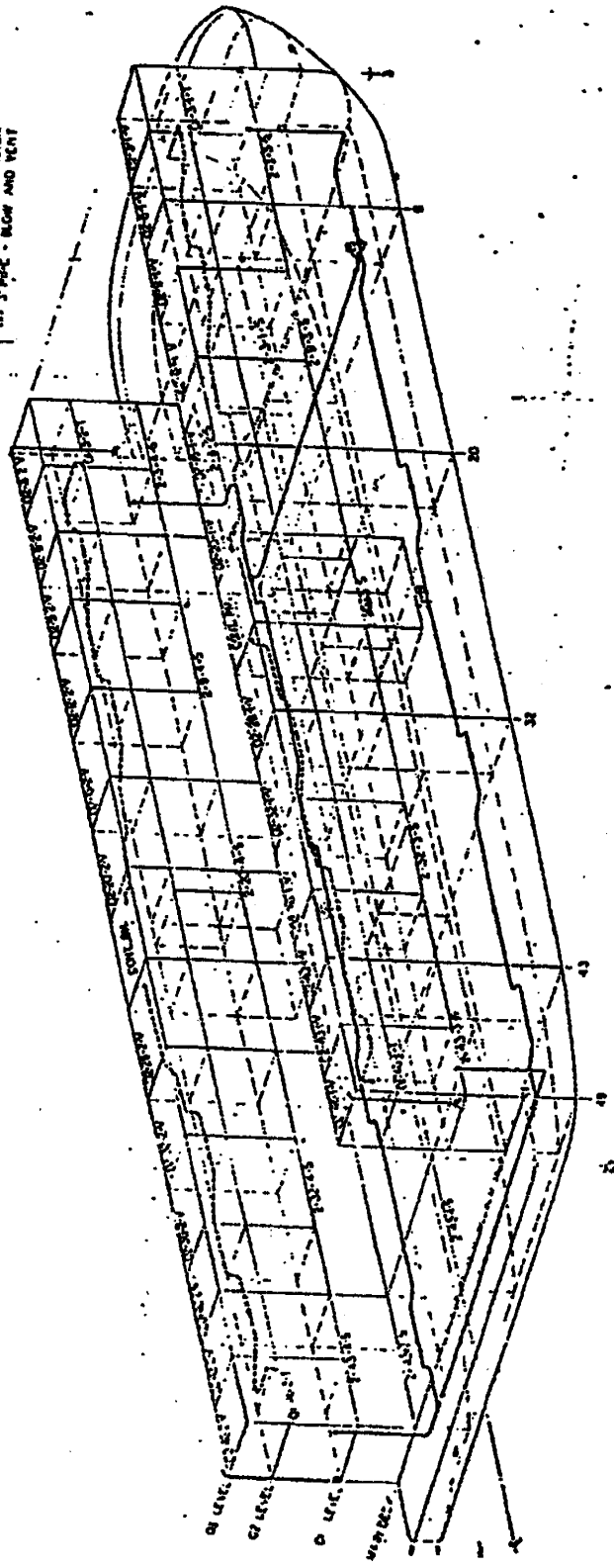

TRAIN TR.
VENT-BLOW- AND TRAN-FLEX SYSTEM

Fig. 1

NO.	REV.	DATE	BY	CHKD.

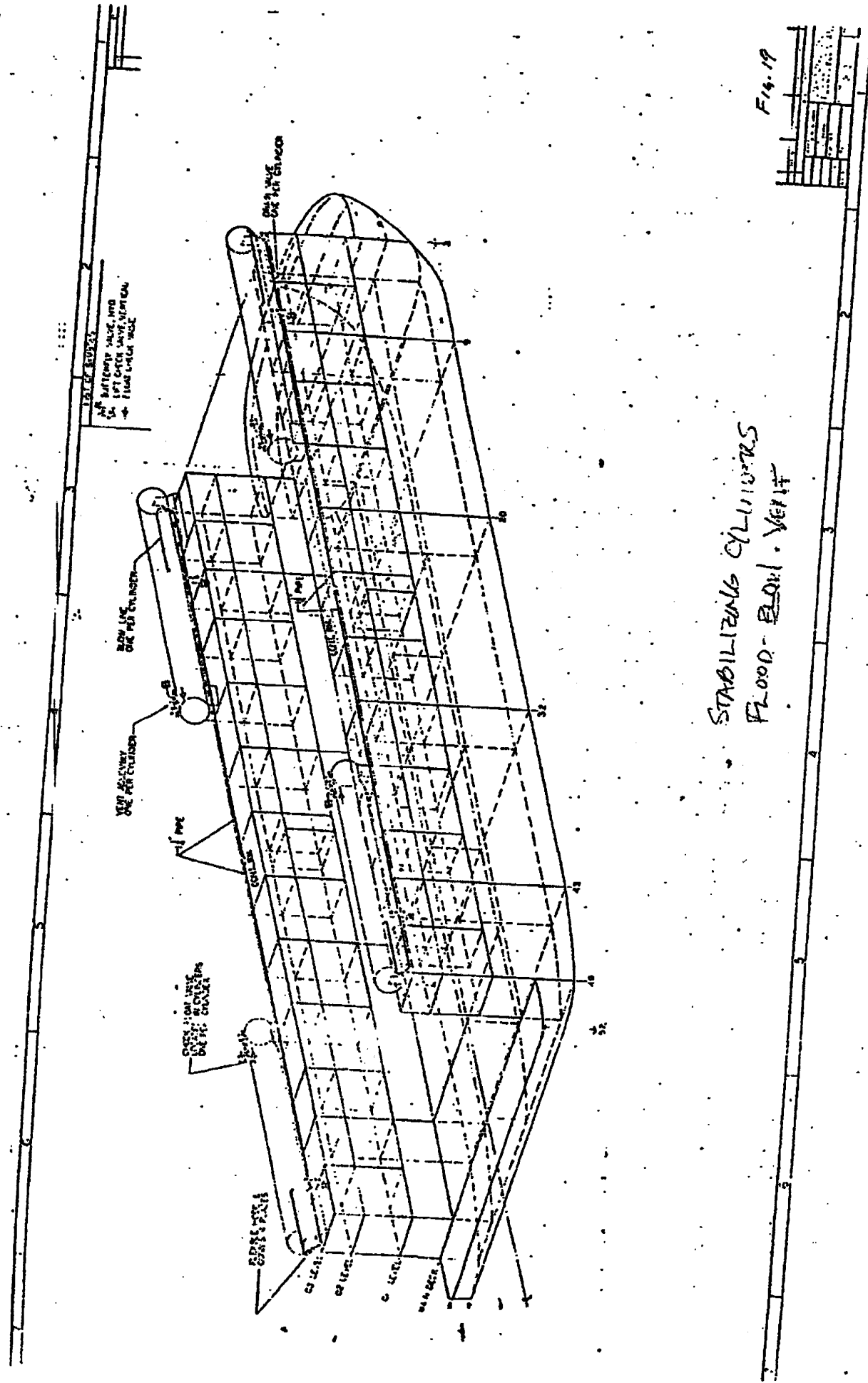

STABILIZING CYLINDERS
FLOOD-ELIM. VENT

Fig. 19

A. INDICATED VALVE, HANG
 B. NO BLEND
 C. RECESSED VALVE ROD

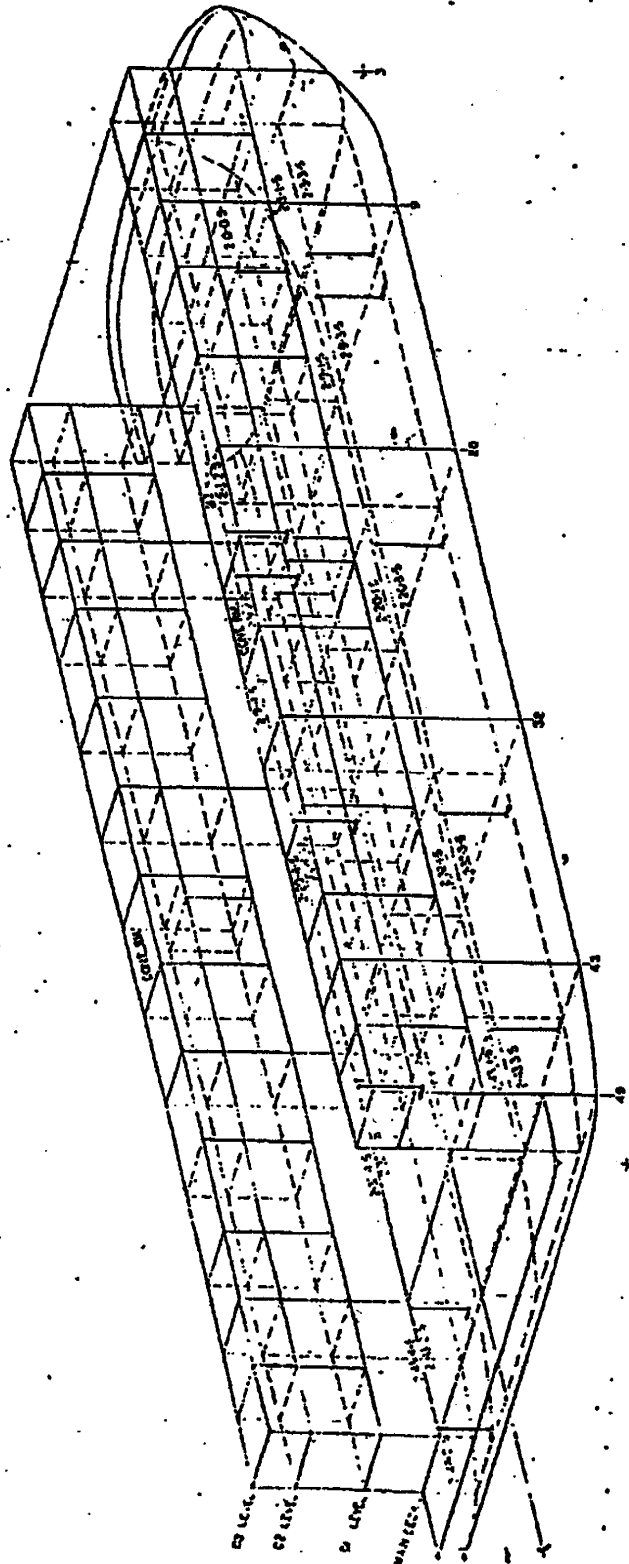

NOTE
 VALVE AND ALL PARTS (AND EACH)
 SHOWN IN CONTROL ROOMS

Emergency Afloat;
 PAXES wing; PONTON TRKS

Fig. 2.0

NO.	REV.	DATE	BY	CHKD.
1				
2				
3				
4				
5				
6				
7				
8				
9				
10				

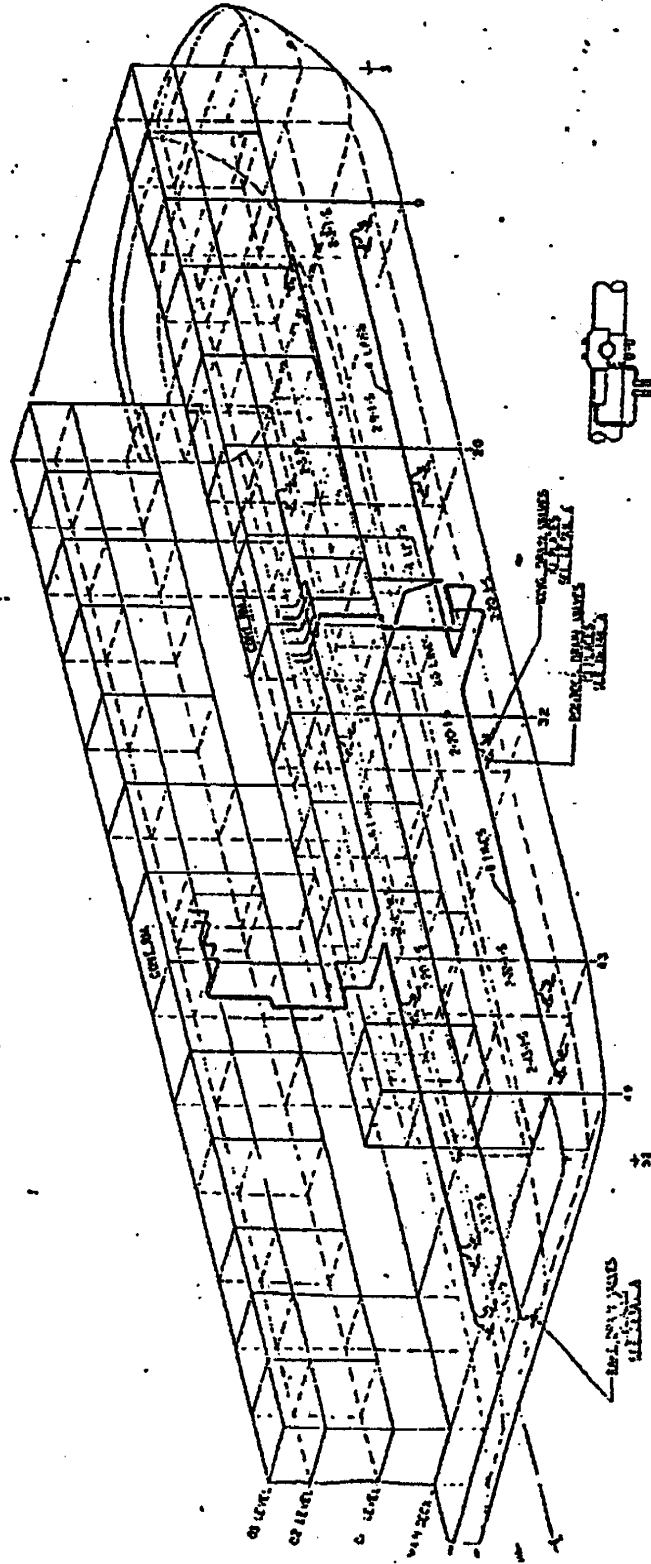

HYDRAULIC LINES

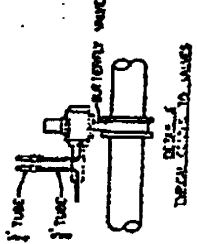

HYDRAULIC LINES, VALVES, FOR PORTLAND, WING, RAKE TIES

Fig. 21

NO.	REV.	DATE	BY	CHKD.
1				
2				
3				
4				
5				
6				
7				
8				
9				
10				

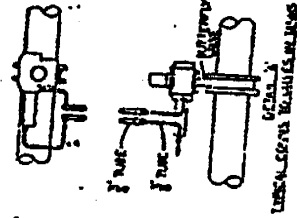
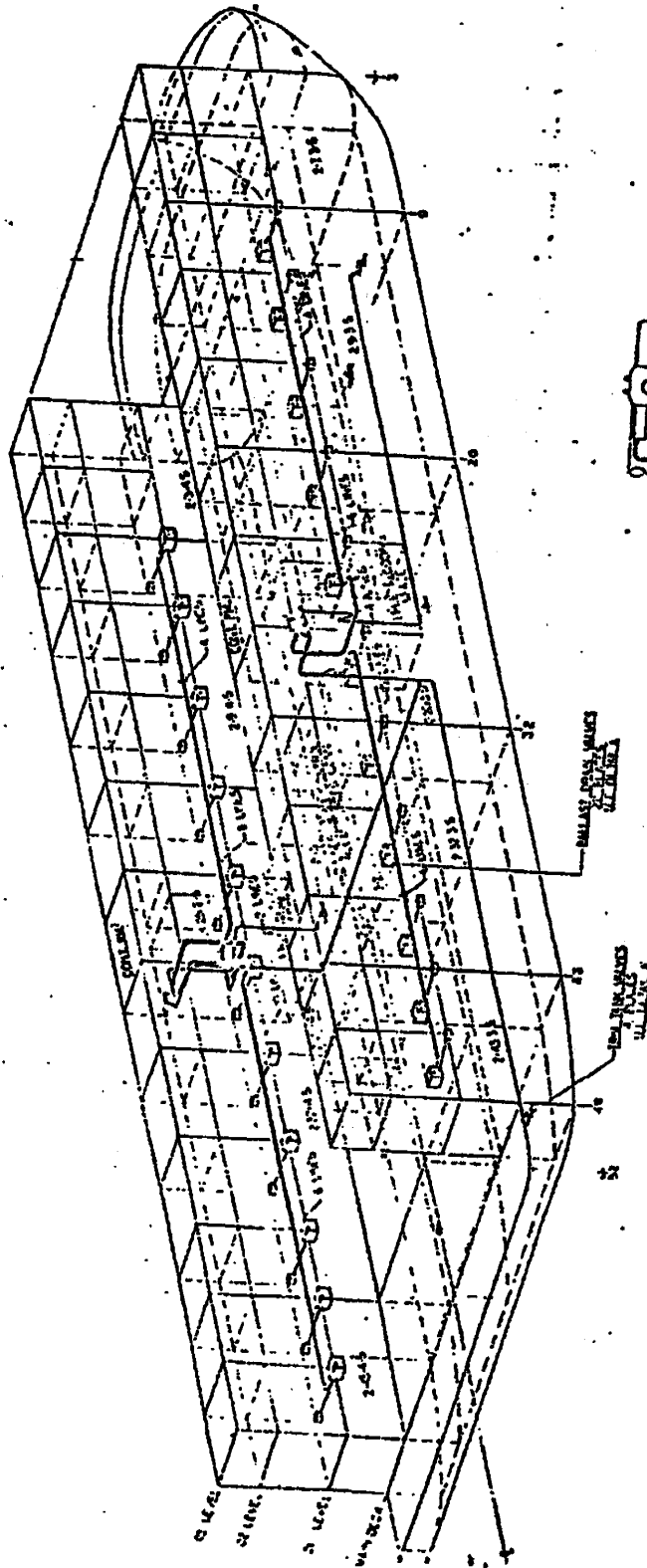

Fig. 2-2

HYDRAULIC LINES & VALVES FOR
 VAPORABLE TRAP TESTS

U

U

U

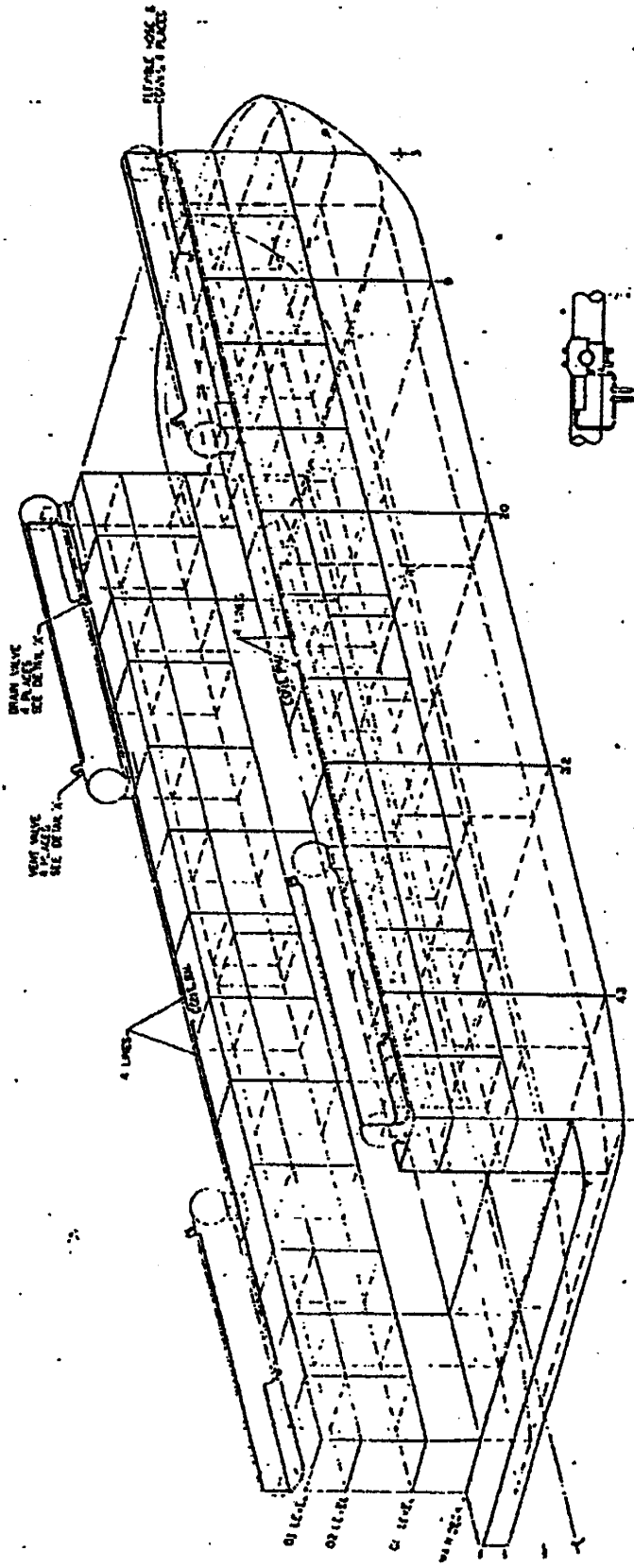

STABILIZER CYLINDERS
 HYDRAULIC LINES & VALVES

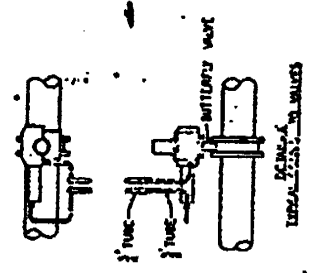
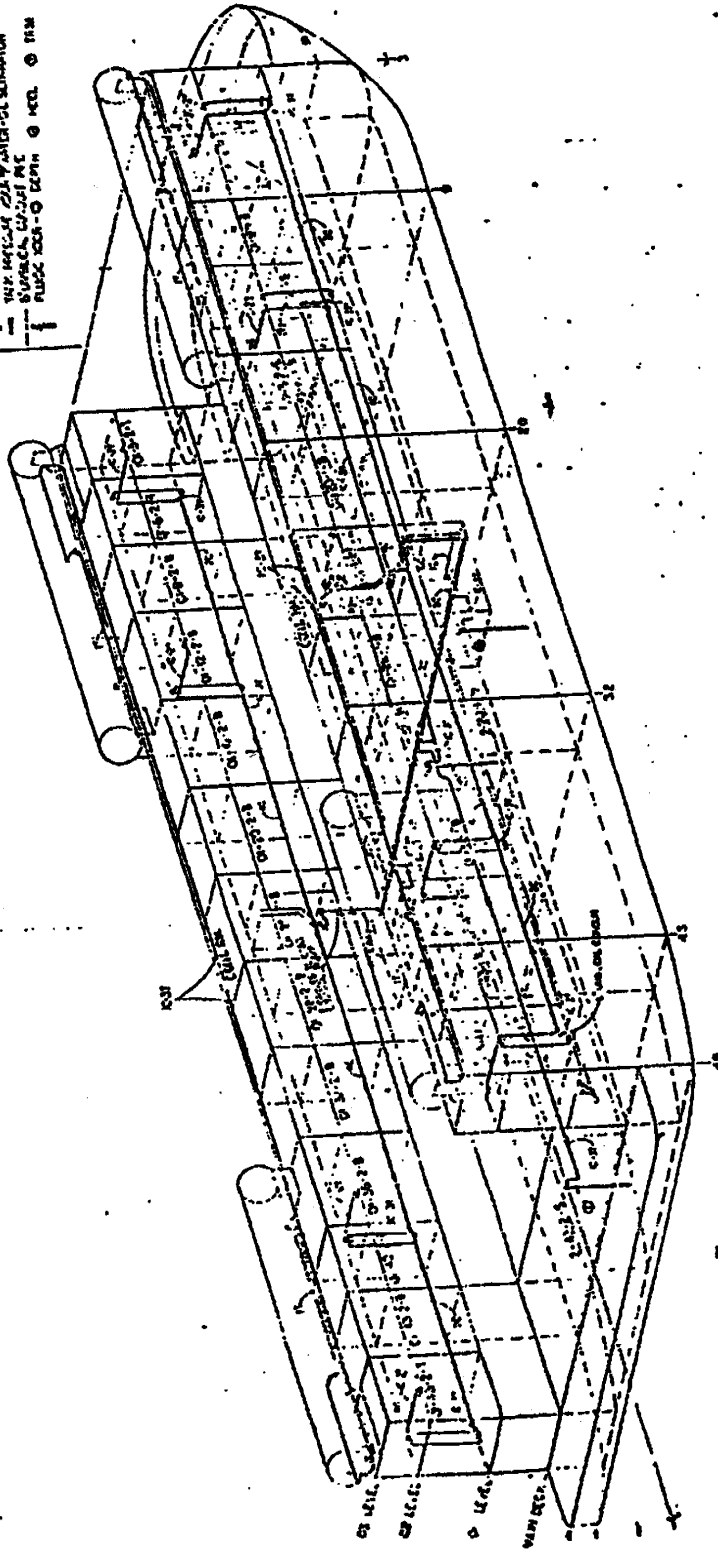

Fig. 23

DATE	APR 1 1954
BY	T. FURRH
CHECKED	
APPROVED	
SCALE	
PROJECT	
DRAWING NO.	
SHEET NO.	
TOTAL SHEETS	

1. ALL DIMENSIONS ARE IN FEET AND INCHES UNLESS OTHERWISE SPECIFIED.
 2. ALL DIMENSIONS ARE TO FACE UNLESS OTHERWISE SPECIFIED.
 3. ALL DIMENSIONS ARE TO CENTER UNLESS OTHERWISE SPECIFIED.
 4. ALL DIMENSIONS ARE TO SURFACE UNLESS OTHERWISE SPECIFIED.
 5. ALL DIMENSIONS ARE TO CENTER UNLESS OTHERWISE SPECIFIED.
 6. ALL DIMENSIONS ARE TO SURFACE UNLESS OTHERWISE SPECIFIED.
 7. ALL DIMENSIONS ARE TO CENTER UNLESS OTHERWISE SPECIFIED.
 8. ALL DIMENSIONS ARE TO SURFACE UNLESS OTHERWISE SPECIFIED.
 9. ALL DIMENSIONS ARE TO CENTER UNLESS OTHERWISE SPECIFIED.
 10. ALL DIMENSIONS ARE TO SURFACE UNLESS OTHERWISE SPECIFIED.
 11. ALL DIMENSIONS ARE TO CENTER UNLESS OTHERWISE SPECIFIED.
 12. ALL DIMENSIONS ARE TO SURFACE UNLESS OTHERWISE SPECIFIED.
 13. ALL DIMENSIONS ARE TO CENTER UNLESS OTHERWISE SPECIFIED.
 14. ALL DIMENSIONS ARE TO SURFACE UNLESS OTHERWISE SPECIFIED.
 15. ALL DIMENSIONS ARE TO CENTER UNLESS OTHERWISE SPECIFIED.
 16. ALL DIMENSIONS ARE TO SURFACE UNLESS OTHERWISE SPECIFIED.
 17. ALL DIMENSIONS ARE TO CENTER UNLESS OTHERWISE SPECIFIED.
 18. ALL DIMENSIONS ARE TO SURFACE UNLESS OTHERWISE SPECIFIED.
 19. ALL DIMENSIONS ARE TO CENTER UNLESS OTHERWISE SPECIFIED.
 20. ALL DIMENSIONS ARE TO SURFACE UNLESS OTHERWISE SPECIFIED.



1. ALL DIMENSIONS ARE IN FEET AND INCHES UNLESS OTHERWISE SPECIFIED.
 2. ALL DIMENSIONS ARE TO FACE UNLESS OTHERWISE SPECIFIED.
 3. ALL DIMENSIONS ARE TO CENTER UNLESS OTHERWISE SPECIFIED.
 4. ALL DIMENSIONS ARE TO SURFACE UNLESS OTHERWISE SPECIFIED.
 5. ALL DIMENSIONS ARE TO CENTER UNLESS OTHERWISE SPECIFIED.
 6. ALL DIMENSIONS ARE TO SURFACE UNLESS OTHERWISE SPECIFIED.
 7. ALL DIMENSIONS ARE TO CENTER UNLESS OTHERWISE SPECIFIED.
 8. ALL DIMENSIONS ARE TO SURFACE UNLESS OTHERWISE SPECIFIED.
 9. ALL DIMENSIONS ARE TO CENTER UNLESS OTHERWISE SPECIFIED.
 10. ALL DIMENSIONS ARE TO SURFACE UNLESS OTHERWISE SPECIFIED.
 11. ALL DIMENSIONS ARE TO CENTER UNLESS OTHERWISE SPECIFIED.
 12. ALL DIMENSIONS ARE TO SURFACE UNLESS OTHERWISE SPECIFIED.
 13. ALL DIMENSIONS ARE TO CENTER UNLESS OTHERWISE SPECIFIED.
 14. ALL DIMENSIONS ARE TO SURFACE UNLESS OTHERWISE SPECIFIED.
 15. ALL DIMENSIONS ARE TO CENTER UNLESS OTHERWISE SPECIFIED.
 16. ALL DIMENSIONS ARE TO SURFACE UNLESS OTHERWISE SPECIFIED.
 17. ALL DIMENSIONS ARE TO CENTER UNLESS OTHERWISE SPECIFIED.
 18. ALL DIMENSIONS ARE TO SURFACE UNLESS OTHERWISE SPECIFIED.
 19. ALL DIMENSIONS ARE TO CENTER UNLESS OTHERWISE SPECIFIED.
 20. ALL DIMENSIONS ARE TO SURFACE UNLESS OTHERWISE SPECIFIED.

Fig. 2-4

FLUIDICS

1 KEY UP AND SLAVE
 2 RIDGER
 3 BEARER PK

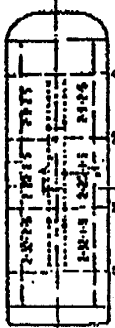
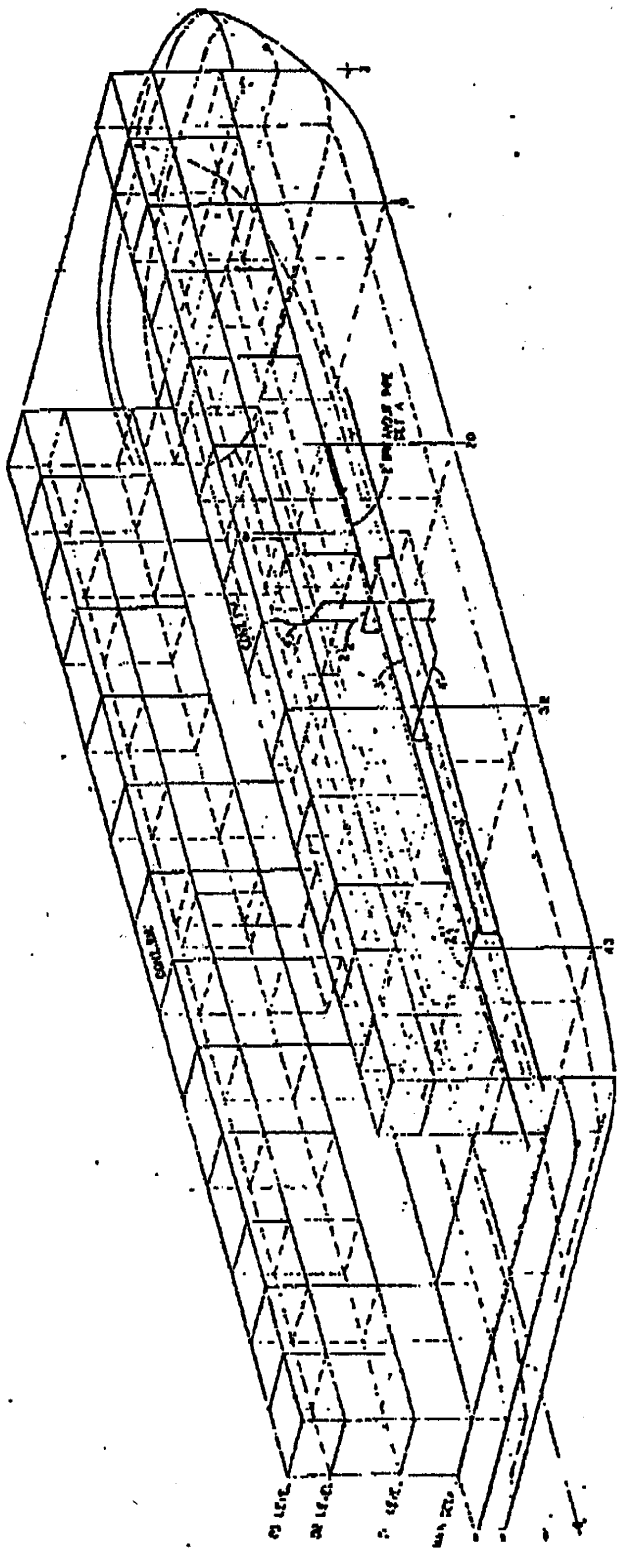

KEY

KEY UP AND SLAVE

KEY

KEY UP AND SLAVE

BOTTOM BREAKOUT SYSTEM

Fig. 25

NO.	REV.	DATE	BY	CHKD.

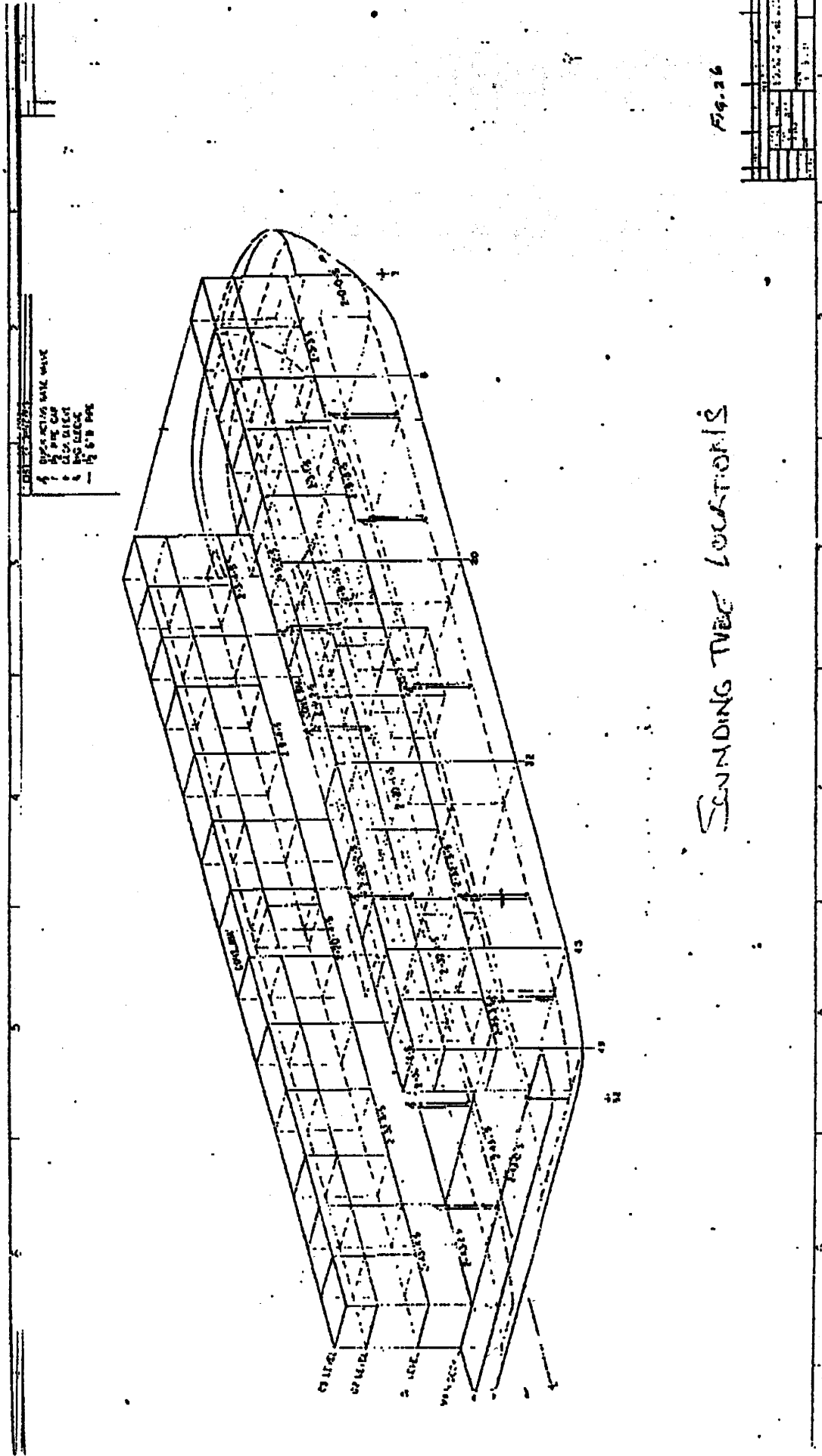

SENDING THE LOCATIONS

Fig. 26

NO.	DESCRIPTION	DATE	BY
1
2
3
4
5

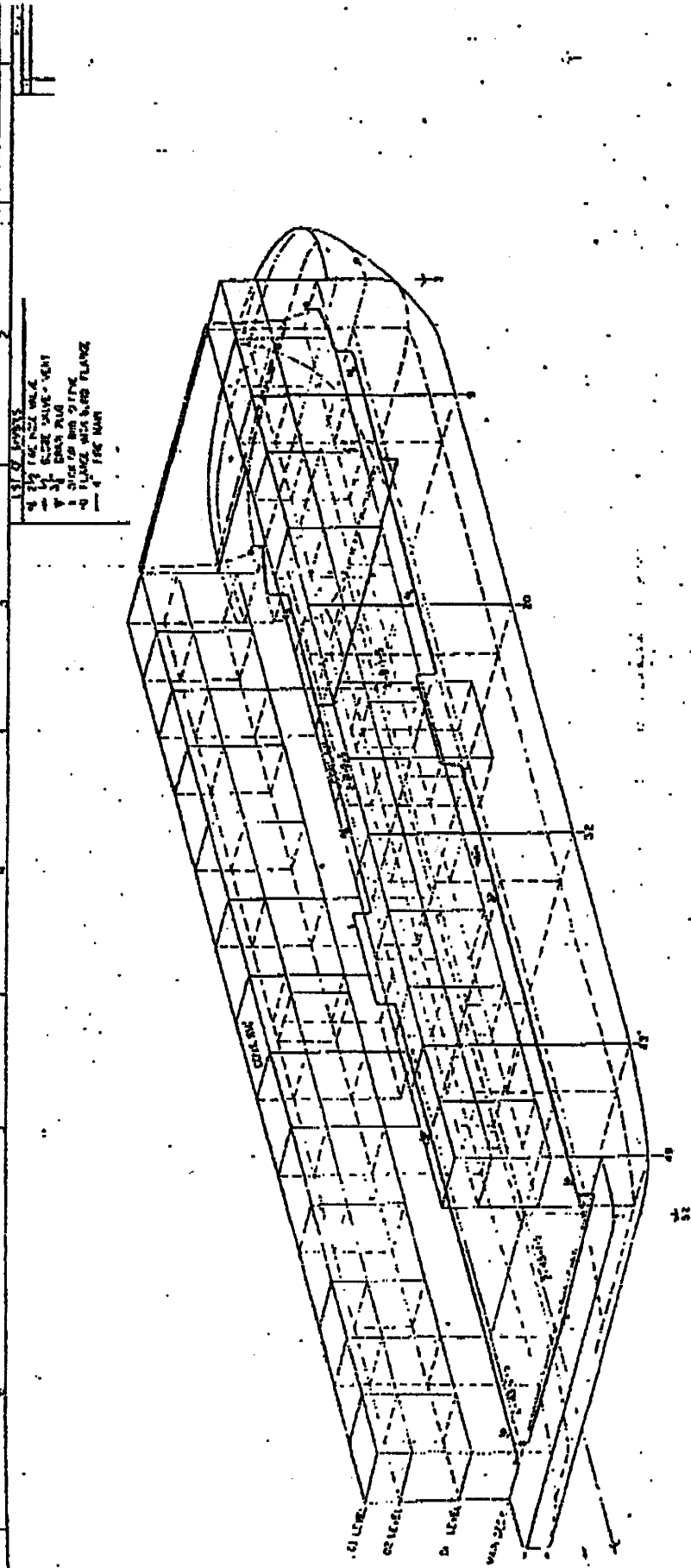

FIRE MAIN

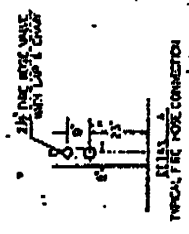

Fig. 27

NO.	REV.	DATE	BY	APP.
1				
2				
3				
4				
5				
6				
7				
8				
9				
10				
11				
12				
13				
14				
15				
16				
17				
18				
19				
20				
21				
22				
23				
24				
25				
26				
27				
28				
29				
30				
31				
32				
33				
34				
35				
36				
37				
38				
39				
40				
41				
42				
43				
44				
45				
46				
47				
48				
49				
50				
51				
52				
53				
54				
55				
56				
57				
58				
59				
60				
61				
62				
63				
64				
65				
66				
67				
68				
69				
70				
71				
72				
73				
74				
75				
76				
77				
78				
79				
80				
81				
82				
83				
84				
85				
86				
87				
88				
89				
90				
91				
92				
93				
94				
95				
96				
97				
98				
99				
100				

Section III

Operating Restrictions & Recommendations

A. Restrictions

The following operating restrictions are referenced by an endorsement on the certificate of inspection, and may not be altered or violated without prior approval of the cognizant Officer in Charge, Marine Inspection, U.S. Coast Guard.

1. The assigned loadline draft shall not be exceeded except when the vessel is moored so as to ensure that it will come to rest on the bottom in water not exceeding 165 feet in depth.
2. During soft tank flooding or dewatering, upper control space hatches shall be secured closed whenever draft exceeds 59 feet. Access or egress through such hatches shall be permitted only when flooding or dewatering is secured. In no case shall the control spaces be manned when any portion of the upper deck is awash, except as permitted for salvage.
3. When the upper deck is submerged, no entrance of personnel shall be permitted into interior spaces of the vessel, where the opening of watertight closures is required, except for repairs or other salvage operations required for flotation of the vessel.
4. Prior to beginning the submergence operation, the ocean bottom in the vicinity of the bottoming site is to be inspected by divers or other means suitable to establish that the bottom is clear of obstructions and free from conditions which could hazard the vessel.
5. (a) No fewer than two pontoon or rake tanks shall be blown simultaneously.
(b) One wing tank may be blown if two pontoon tanks are being blown simultaneously.
(c) The minimum number of wing tanks blown simultaneously shall be limited to three tanks at drafts less than 22 feet, four tanks at drafts between 22 and 28 feet, or six tanks at drafts greater than 28 feet.
(d) After the maximum amount of water has been blown from the wing tanks, following restriction 5(c), wing tanks may be blown individually to ensure

compliance with restriction 6, provided that air supply is reduced to one compressor and manifold pressures are monitored continuously.

- (e) A minimum of three wing tanks and one variable tank, or one wing tank and two variable tanks shall be blown simultaneously.
6. In order to provide positive transverse and longitudinal stability during flooding and blowing operations, wing tanks 2-9-3, 2-9-4, 2-20-3, 2-20-4, 2-32-3, 2-32-4 shall be empty whenever any pontoon tanks are slack.
 7. Care shall be exercised to ensure that all soft tank flood valves are open before beginning emergence operations.
 8. Care shall be exercised to ensure that support vessel characteristics are such that the safety of the submersible construction barge is not compromised.
 9. A log shall be kept of all submergence operations. This log shall contain the following information:
 - (a) Dates and times of submergence and emergence.
 - (b) Depth of submergence.
 - (c) Geographical position of submergence.
 - (d) Times, durations, and circumstances surrounding entry into the control space while submerged.
 - (e) Minimum water temperature adjacent to the submerged barge.
 - (f) Report of completion of required bottom investigations.
 - (g) Major operational changes and events of special significance.
 10. Materials of unusual flammability, spark or ignition sources, and materials presenting a serious risk of atmospheric contamination shall not be present in either of the control spaces while the construction barge is submerged. Care shall be taken to ensure that engine exhaust gases or other potentially dangerous atmospheric contaminants are not introduced into the submerged control spaces via the air supply system.
 11. Care shall be taken that current velocities, surface vessel traffic, and other conditions of the submerged operation do not present a significant hazard to the safety of the construction barge.

12. When operating in the submerged mode, the control space atmosphere shall be thoroughly flushed (ventilated) before salvage personnel are allowed to enter.
13. Means shall be provided for routine and emergency diver decompression. Procedures for using these means shall be established.
14. Before undertaking repairs, alterations, or modifications, including any welding, to the pressure-resistant structure particular attention should be given to the requirements of 46 CFR 189.45-1 to determine whether prior approval by the Coast Guard is required.
15. The internal pressure of the control spaces shall not be raised above 25 p.s.i.a. except when it is necessary to do so in order to prevent control space flooding. Salvage personnel entering the control space under such conditions shall be equipped with a breathing gas supply which is completely independent of the control space atmosphere.
16. Safe operation of the HMB-1 depends to a great extent on the operation of the surface support vessel (work barge) and its portable installed support equipment. After this support equipment has been installed on a suitable work barge, a Coast Guard inspection will be required before any operation involving HMB-1 is conducted.
17. The nearest officer in Charge, Marine Inspection shall be notified at least 30 days prior to any operation of HMB-1.

B. Recommended Operating Practices

The following operating practices have been recommended by the U.S. Coast Guard to enhance the safe operation of the vessel, but are not a required condition of certification.

1. Submergences and emergence operations should be conducted during daylight hours only.
2. The Owner-operator should request that the Coast Guard District Commander, in whose district operations are taking place, issue a Notice to Mariners when anticipated operations are such that the submerged construction barge offers a potential hazard to navigation or when normal surface traffic could hazard the submerged barge or its support vessel. The Coast Guard operates a voluntary submersible vessel operations reporting system which would serve this purpose.
3. Care should be taken to insure that diving personnel are properly qualified. At submergence depths in excess of 75 feet, diver susceptibility to nitrogen narcosis should be considered.
4. If it is ever necessary for personnel to enter the control spaces while those spaces are in a hyperbaric condition and while the barge is at or near its maximum rated operating depth, care should be taken to limit the duration of their exposure so as to avoid the possibility of oxygen poisoning.

(The U.S. Navy Diving Manual sets a two-hour normal maximum exposure time for a 1.1 atmospheric partial pressure of oxygen and a four-hour maximum for a 1.0 atmosphere)

Section IV

Operating Sequences

A. General

The following operating sequences have been prepared for a typical cycle of submergence, submerged payload change, and resurfacing. A water depth near the maximum design depth has been assumed.

Details of anchoring and umbilical deployment will vary with site conditions and available surface equipment, and must be planned accordingly.

In the case of shallow depth operations, or other particular circumstances, certain steps given here may be eliminated or repeated. However, care must be exercised not to overlook essential precautions if the sequence of operations is varied from that indicated here.

B. Summary of Ballast Tank Valve Positions

Normal valve positions are given in the operating sequences and in the system descriptions (Section II). However, the normal ballast tank vent, blow, and sea valve positions at the end of each operating step are summarized in the following table for quick reference.

Note that the following precautions must be observed.

1. Whenever draft exceeds approximately 54 feet, it is possible for empty tanks to fill through other filled tanks via the vent manifold, if vent valves on both full and empty tanks are left open.

2. Whenever the CB is ascending, or could possibly ascend inadvertently, all tanks should have some means, through either sea valves or vent valves, of relieving excess internal air pressure.

3. Whenever possible, tanks should be vented to preclude overpressure or unwanted buoyancy due to inadvertent leakage of blow valves.

At End of Step No.	Description	Pontoon Tanks			Wing Tanks			Variable Tanks		
		Tank Condition	Sea Valve	Vent Valve	Tank Condition	Sea Valve	Vent Valve	Tank Condition	Sea Valve	Vent Valve
1	Preflood Check	E PF	C C	O O	E PF	C C	O O	E C	C C	O O
2	Pontoon Tank Flooding	E PF F	C C O	O O O	E PF	C C	O O	E C	C C	O O
3	Combined Pontoon and Wing Flooding				E PF F	C C O	O O C	E C	C C	O O
4	Wing Tank Flooding				PF F	C O	C C	E C	C C	O O
5	Combined Wing and Variable Flooding							E PF F	C C O	C C C
6	Pre-dive Check	F	O	O	F	O	O	Unchanged		
7-10	Diving and Flooding on Bottom	Unchanged						E PF F	C C O	C C C
11-14	Blowing, On Bottom or To Ascend	Unchanged						E PF F	C C O	O O C
15	Preparation for soft tank blowing	F	O	C	F	O	C	E PF F	C C C	O O O
16	Combined Wing and Variable Tank Blowing	F	O	C	E PF F	O O O	C C C	E C	C C	O O
17	Wing Tank Blowing	F	O	C	E PF F	C C C	O O O	E C	C C	O O
18.	Combined wing and pontoon tank blowing	E PF F	O O O	C C C	E	C	O	E	O	O
19	Pontoon Tank Blowing	E PF F	C C C	O O O	E	C	O	E	O	O

Note, when draft reaches 30 feet.

Symbols:

Tank Condition
 E - Empty
 PF - Partly Full
 F - Full

Valve Position

O - Open
 C - Closed

G. Procedure**Step 1. Checklist, Preparation for Flooding**

INITIAL CONDITION: Moorings and Umbilicals ready for diving.

OPERATIONSREFER TO

- | | |
|---|-----------------------------|
| a. Check for free flooding:
Aft bulkhead ports unpinned.
Main deck access doors P/S secured open.
Chain locker drains open.
Forecastle deck access door open. | |
| b. Check exterior machinery ready for submergence:
Boom winches.
Anchor windlasses.
Roof machinery. | |
| c. Check soft tank emergency blow valves closed. | Sect II, Fig. 20. |
| d. Remove non-waterproof equipment to WB:
CO2 fire extinguishers.
Navigation lights and batteries. | |
| e. Release lashings on cylinders. | |
| f. Read draft marks. | |
| g. Enter control spaces, securing inboard wetlock doors closed, outboard doors open. Check all wetlock valves in normal position, and close and dog O2 level hatch. | Sect II, Fig. 4. |
| h. Establish telephone communications with WB. | |
| i. Check all tank valve positions, including cylinders: Sea valves closed, vent valves open. | Sect II, Figs 6,7,8, and 9. |
| j. Mechanical system check: | |
| (1) Ballast air supply @ 100 psi P/S. | Sect II, Fig. 1 |
| (2) Constant pressure air supply @ 100 psi P/S. | " " 2 |
| (3) Hydraulic primary pressure, 1700 to 2000 psi. | " " 3 |
| (4) Hydraulic secondary pressure, 1000 psi P/S. | " " 3 |
| (5) Space air supply flowing normally. | " " 1 |
| (6) Check atmospheric reference tank valve to space open. | " " 5 |
| (7) Check control location selector switches in "Local" position (stbd control space). | |

Step 1, cont'd

OPERATIONS

REFER TO

- k. Check all vent manifolds open overboard.
- m. Check out fluidic system:
 (1) Flow meter readings normal.
 (2) Verify draft, trim, and list with draft marks.
- n. Pressurize soft tank blow manifolds.

Sect I, Figs 6 & 7.

Sect II, Fig. 1.

FINAL CONDITION: Ready for diving.

ESTIMATED TIME:

MANNING: Control Space Port
 " " Stbd
 Surface Control Station

Step 2. Pontoon Tank Flooding

INITIAL CONDITION: Normally, tanks will be ballasted as for sea towing, Section I. Maximum draft: Assigned load line.

OPERATIONS	REFER TO
a. Start flooding all pontoon and rake tanks.	Sect II, Fig 6.
b. Control attitude by closing flood valves on primary, or if necessary, secondary pontoon tanks.	Sect VI, B,1,a.
c. Maintain attitude within the following limits: List: ± 2 ft (1 degree). Trim, when draft is less than 18 ft: Minus zero, by head. Plus 2 ft (0.4 deg.) by stern. Trim; when draft is greater than 19 ft: ± 7 ft (1.3 deg.).	Note 1
d. Continue until all possible tanks are flooded full, or to waterline.	Note 2 Note 3
e. Leave sea valves and vent valves open on filled tanks.	

FINAL CONDITION: Max draft:
Min draft:

ESTIMATED TIME:

MANNING, Unchanged

NOTES

1. If list exceeds given limits while a soft tank is being pressed up, air will be trapped in outboard corners of tanks on the high side. Once both vents are covered in a given tank, and the portions of the vent lines sloping downward to the wing wall are flooded, this air cannot be vented by merely correcting the list condition. The tank must be blown down at least three feet to drain the vent lines, then reflooded with zero list.

Trim should be maintained during final flooding of pontoon tanks, so that after the vent at the low end of the tank has flooded out, the remaining air will be concentrated at the high end, and maximum air purging will result.

CAUTION: It is essential that the flooded tanks have a minimum of air retained, since any bubbles will tend to compress, and impair the controllability of the vessel during diving. If desired, the vent plugs for each pontoon tank in the main deck may be removed prior to flooding the tanks in order to ensure that all air will be expelled. With payloads having regions which are possible sources of entrapped air, vent plugs should normally be removed.

Filled condition of tanks can be determined by closing vent valves slowly and listening for air flow through partially closed valve.

2. Normally, no more than two primary tanks will be left partially flooded. Flood diagonal pairs until one tank in pair is full.

3. With small payload, flooding rates may be very slow near 16-foot draft. If necessary, proceed to next step.

Step 3. Combined Pontoon and Wing Tank Flooding

INITIAL CONDITION: Max Draft:
Min Draft:

OPERATIONS

- a. Flood remaining pontoon tanks.
- b. Simultaneously, start flooding any primary (or, if necessary, secondary) wing tanks diagonally opposite from unfilled pontoons.
- c. Control attitude by number of wing tanks being flooded, within the limits given in Step 2.
- d. Continue until all remaining pontoon tanks are flooded.
- e. Close vent valves, leave sea valves open on filled tanks. Close seawalves, leave vent valves open on unfilled wing tanks.

REFER TO

Sect II, Fig 6.

Sect II, Fig 6.
Sect VI, B, 1, b.

Sect VI, B, 1, c.

FINAL CONDITION: Max draft:
Min draft:

ESTIMATED TIME:

MANNING: Unchanged.

Step 4. Wing Tank Flooding

INITIAL CONDITION: Max Draft:
Min Draft:

OPERATIONS

- a. Start flooding all remaining wing tanks.
- b. Control attitude by closing sea valves and vent valves on primary wing tanks as necessary.
- c. Continue until all but two primary wing tanks (or additional secondary wings if necessary) are pressed up. Stop flooding by closing sea valves and vent valves on unfilled wing tanks.
- d. Secure all pressed-up wing tanks with sea valves open, vents closed.

REFER TO:

Sect II, Fig 6.

Sect VI, B, 1, c.

Sect VI, B, 1, c.

Sect II, Fig 6.

FINAL CONDITION: Max. Draft:
Min. Draft:

ESTIMATED TIME:

MANNING: Unchanged.

Step 5. Combined Wing and Variable Tank Flooding

INITIAL CONDITION: Max Draft:
Min Draft:

OPERATIONS	REFER TO
a. Check that all systems are ready for variable tank flooding, with local control.	Sect II, Figs 7 & 13.
b. Hinge O3 level control space access hatches down closed, but do not engage dogs.	
c. Charge trim system if not already done.	Sect II, Fig 8 Sect VI, C, 1.
d. Flood remaining wing tanks and unsymmetrical VB tanks. Transfer trim ballast and fill IVB tanks as required for diving. At this time, do not fill any tanks which will be used in symmetrical diving groups.	Sect II, Figs 6,7,8. Sect VI, C.
e. Secure remaining wing tanks with sea valves open, vents closed, when pressed up.	
f. Report filled VBs to control station for logging on status board.	

FINAL CONDITION: Max Draft: 62 ft (up to O3 level)
Min Draft:

ESTIMATED TIME:

MANNING: Unchanged.

Step 6. Pre-dive Checkoff List

INITIAL CONDITION:

OPERATIONS

REFER TO

Ensure that the following conditions exist before leaving the CB control space:

- a. Control space hatch to wet lock closed.
- b. Wetlock doors closed with wet lock flooded.
- c. Wetlock pressure equal to ambient water pressure.
- d. Sea and vent valves set as tabulated in valve position table, step 6.
- e. All blow valves closed.
- f. Valves serving wet lock set correctly.
- g. Both direct space supply valves closed.
- h. Space vent valve open.
- i. Normal space supply system operating correctly.
- j. All boundary root valves open.
- k. Electrical "Control Location Selector Switch" set to "Remote".
- m. Control transfer has occurred. Have WB cycle some remote operated valves as convenient, check that valves operate properly.
- n. O3 level hatch closed and dogged.

Sect II, Fig 4.
See GA-1 and
depth gauge.

Sect IV-B.

Sect II, Fig 4.

Sect II, Figs 2 & 5.

Sect II, Fig 5.

Sect II, Fig 1.

Sect II, Figs 1
through 8.

Sect II, Fig 13.

NOTE: Items a through j, and n are also applicable to port control space.

Step 6, cont'd.

FINAL CONDITION: Max Draft 6 ft.

ESTIMATED TIME:

MANNING: Unchanged.

Step 7. Variable Tank Flooding, Surface

INITIAL CONDITION: Max Draft: 62 ft
Min Draft:

OPERATIONS

REFER TO...

- a. If remaining freeboard, sea conditions, etc., permit, start flooding symmetric variable tanks.
- b. At discretion of deckmaster, stop flooding all variable tanks. Abandon control spaces. Close and dog hatches.
- c. Divers close and dog outboard wetlock doors P/S.
- d. Remove crew to surface control station.

Sect II, Fig 7.
Sect VI, C, 1.

Sect II, Fig 7.

FINAL CONDITION: Max Draft:
Min Draft:

ESTIMATED TIME:

MANNING: Unchanged.

Step 8. Diving

INITIAL CONDITION: Max draft: 62 ft
 Min draft:

OPERATION	REFER TO
a. During dive, monitor draft, trim, and list indication continuously.	Sect II, Fig 1.
b. Flood symmetrical diving group until draft reaches approximately 61 feet. Stop flooding. Adjust attitude to zero-zero with IVBs (if freeboard permits) or with trim system.	Sect II, Fig 7. Sect VI,C,1.
c. Flood not more than 4 tanks in symmetrical diving group until 03 level submerges (62-ft draft).	
d. When 03 level submerges, reduce flooding to one diagonally opposite pair in diving group, until roof submerges and cylinders are nearly erect (95-ft draft). Stop flooding of the two tanks simultaneously.	
e. Wait 5 to 10 minutes for draft and attitude to stabilize.	
Check all indication for normal readings.	
Ensure that draft, trim, and list are either constant, or oscillating about a mean value.	
Adjust attitude to zero-zero, preferably with IVBs.	
f. Resume flooding in diving group, using only two diagonally opposite tanks at a time, until draft reaches 125 feet.	
g. At 125-ft draft, stop flooding to reduce descent velocity. Then flood one diagonal pair intermittently until draft is stabilized at about 140 feet.	
h. Trim to zero-zero, using diving group, IVBs, or trim system.	

Step 8, cont'd

OPERATIONS

REFER TO

- i. Flood one diagonal pair intermittently. (If desired, use flood valves only, not vent valves for faster operator response). Monitor cylinder freeboard visually from WB.
- j. When cylinders submerge, stop flooding. Prepare to blow one filled diagonally opposite pair if necessary. No further flooding should be necessary.
- k. If trim or list develop during free dive, do not attempt to correct, except by blowing to regain cylinder freeboard.
- m. If diving rate exceeds one foot per second, blow pair selected in j above momentarily. If this results in over-correction (ascent), do not counterflood. Return to cylinder freeboard, reflood blown pair, and repeat free dive.
- n. When CB bottoms, open all four cylinder flood valves (not vent valves), and fill at least 1/3 full. (Or otherwise obtain approximately 200 L.T. negative buoyancy).

Sect II, Fig 7.
Sect VI, C, 1.

Sect II, Fig 9.
Sect VI, C, 2.

FINAL CONDITION: CB on bottom with at least
200 L.T. negative buoyancy

ESTIMATED TIME:

MANNING: Surface.

Step 9. Cylinder Flooding

INITIAL CONDITION: CB on bottom. Cylinders empty (or filled up to 1/3 full if used to obtain bottom reaction).

OPERATIONS

REFER TO

- a. Monitor cylinder levels. Fill all four cylinders with vent valves closed until flooding rate reduces noticeably due to trapped bubble.
- b. Open vent valves on all four cylinders to continue flooding until indicated levels stop increasing. Close vent valves. If indicated levels (now angles) start decreasing, close flood valves.
- c. Complete flooding one cylinder at a time. Note the CB trim angle. This will indicate the angles (plus or minus) at which the cylinders will come to rest on saddles.
- d. Flood by opening vent valve. When angle starts to decrease, cycle vent valve to control descent rate. If response (decreasing rate) to closing vent valve is slow, close sea valve and wait for descent to stop. If necessary, finer control may be obtained by cycling sea valve open occasionally until descent stops, cycling vent valve open once, then repeating.
- e. When angle above deck is less than ten degrees, cylinder descent should be allowed to stop completely after each cycle of valve.
- f. When cylinder is resting in saddle open flood and vent valves, and allow to flood completely. Leave these valves in open position.

Sect II, Fig 9.

FINAL CONDITION: Min bottom reaction, 630 long tons.

ESTIMATED TIME: 40 minutes.

MANNING:

IV-15

Step 10. Flooding Tanks on Bottom

Optional step to be performed as required.

OPERATIONS

REFER TO

- a. Open flood valve(s).
- b. Ensure that vent valves on all empty tanks are closed (particularly tanks which have been blown).
- c. Open vent valve.
- d. When bubbles stop rising to surface, tank(s) are filled. Leave valves open.

Sect II, Fig 7.



Step 11. Blowing Tanks on Bottom.

Optional step to be performed as required.

OPERATIONS

REFER TO

- a. Monitor draft and manifold pressure continuously.
- b. Observe blowing restrictions.
- c. Close vent valves on tanks to be blown.
- d. Ensure that sea valves have been opened.
- e. Open blow valves, on at least the minimum permissible number of tanks, simultaneously.
- f. When air bubbles appear at surface, close blow valves. Then close sea valves. Open vent valves, and leave open unless additional tanks are to be flooded.

Sect II, Fig 1.

Sect III

Sect II, Fig 7.

Step 12. Preparation for Ascent

INITIAL CONDITION: CB resting on bottom with sufficient negative buoyancy to permit erection of cylinders without lifting off.

OPERATIONS**REFER TO**

- | | |
|--|-------------------|
| a. Adjust trim and list moments to zero. | Sect VI,C,1. |
| b. Close vent valves on all completely flooded tanks. | Sect II, Fig 7,8. |
| c. Open vent valves on all partially flooded or empty tanks. | " " " " " |

Step 13. Blowing Cylinders

INITIAL CONDITION: As in Step 21.

OPERATIONSREFER TO

- a. Monitor manifold pressures and draft continuously.
- b. Close all cylinder vent valves.
- c. Open all cylinder blow valves simultaneously.
- d. Blow until empty. Angle/level indicators will increase to maximum angle, then decrease again to zero level.
- e. Close blow valves.
- f. Close sea valves.
- g. Open vent valves, and observe that level indications remain at zero. Leave vent valves open.

Sect II, Fig 1.

Sect II, Fig 9.



Step 14. Blowing Variable Tanks

INITIAL CONDITION: CB on bottom, slight negative buoyancy.

OPERATIONS	REFER TO
a. Monitor manifold pressures, draft, trim, and list continuously.	Sect II, Fig 1.
b. Observe blowing restrictions.	Sect III
c. If possible, blow IVBs to slight positive buoyancy, to observe for bottom suction.	Sect II, Fig 7.
d. If bottom suction is apparent, increase positive buoyancy gradually. If breakout force exceeds 150 L.T., use breakout air system.	Sect II, Fig
e. When liftoff occurs, stop all blowing, leaving sea valves open on tanks being blown.	Sect II, Fig 7.
f. When tops of cylinders broach surface, close sea valves on the tanks which were being blown at time of liftoff.	
g. Allow draft to stabilize.	
h. Any tanks which are blown completely or partially during liftoff or ascent, should be secured with sea valves closed and vent valves open before proceeding with ascent using other tanks.	
i. Open sea valves and resume blowing symmetric diving group.	
j. Cycle trim tank vents open several times during ascent.	Sect II, Fig 8.
k. When O3 level broaches surface, open cylinder sea valves and cycle trim tank vents open.	Sect II, Fig 7 & 8.
m. As many VB and IVB tanks as possible should be blown before personnel board CB. In particular, blow tanks 25 P/S, and if possible, blow other tanks in vicinity of control spaces.	Sect II, Fig 7.

Step 14, cont'd.

OPERATIONS

REFER TO

- n. Secure blowing, close all sea valves,
and open all vent valves.

Sect II, Fig 7.

Step 15. Preparation for Soft Tank Blowing

INITIAL CONDITION: Unmanned, all hard tanks vented.

Max. Draft: 62 feet

Min. Draft: 52 feet

OPERATIONS

REFER TO

- | | |
|---|---|
| <ul style="list-style-type: none"> a. Board CB. Crews should be landed separately on port and starboard sides, immediately adjacent to control space hatches. They should proceed immediately to hatches, enter control spaces, and close hatches (without dogging) behind them. No personnel should be on deck during hard tank blowing operations. b. Check position of all hard tank vent and blow valves. Blow valves should be closed and vent valves should be open. c. Establish communications. Transfer to local control. d. Position all soft tank vent/blow valves from vent to close. | <p>Dwg 7043+20.</p> <p>Sect II, Fig. 7.</p> <p>Sect II, Fig. 6.</p> |
|---|---|

FINAL CONDITION: Max. Draft: 62 feet.
Min. Draft: 52 feet.

ESTIMATED TIME:

MANNING: Remote Control, 3.
Stbd Control, 3.
Port Control, 2.

Step 16. Combined Wing and Variable Tank Blowing

INITIAL CONDITION: Manned, with local hard tank control.
 Max. Draft: 62 feet.
 Min. Draft: 52 feet.

OPERATIONS

REFER TO

- a. Monitor manifold pressures continuously.
- b. Observe blowing limitations.
- c. No personnel should be permitted to leave control spaces during hard tank blowing.
- d. Blow remaining variable tanks in combination with appropriate primary wing tanks until all variable tanks are empty. Transfer trim system ballast as necessary.
- e. Secure blown variable tanks with sea valves closed and vent valves open. Secure blown wing tanks sea valves open and vent valves closed. Wing tanks shall not be vented to atmosphere.
- f. Check all hard tank vent valves open by direct observation in control spaces P/S. Cycle trim tank vents open and observe actual valve operation.

Sect II,
 Figs 6 & 7.

FINAL CONDITION: Max. Draft: 62 feet.
 Min. Draft: 52 feet.

ESTIMATED TIME:

MANNING: Unchanged.

Step 17. Wing Tank Blowing

INITIAL CONDITION: Maximum draft
Minimum draft

OPERATIONS**REFER TO**

- a. Monitor manifold pressures continuously.
- b. Observe blowing limitations.
- c. Blow all wing tanks, using primary wings to control trim and list.
- d. When draft reaches 30 feet, open all VB and IVB sea valves to drain empty.
- e. At drafts less than 30 feet, after hard tank sea valves have been opened, the O3 level control space hatches may be opened fully. Personnel may be permitted to leave the control spaces briefly to observe air emitting from sea valves and verify that tanks are empty. Access shall be limited to the O3 deck in the immediate vicinity of the control space hatches.
- f. As individual wing tanks are blown empty, they shall be secured with sea valves open and vent valves closed. Blow valves may be closed or throttled to achieve desired manifold pressure.
- g. When all wing tanks, except the two primary tanks needed to control attitude, appear to be empty, cycle blow valves to open. Ensure empty tanks by observing air emitting in way of sea valve and by appropriate reduced manifold pressure.
- h. When all empty tanks have been cycled, check draft boards to ensure that drafts forward and aft are less than 41 feet.
- i. Vent wing tanks to atmosphere as follows: Check that all wing tank vent/blow valves are closed, then close sea valves and position vent/blow valves to "Vent" on all empty wing tanks. Wait for air flow to cease, and check that no change in draft or attitude occurs.

Sect II, Fig 6.

Note 1.

Note 2.

Step 17, cont'd .

FINAL CONDITION: Maximum Draft: 29 feet.
Minimum Draft: 20 feet.

NOTES

1. Venting of a wing tank at drafts in excess of 30 feet may result in overloading of internal structural boundaries if an adjacent tank is blown. Open sea valves are used to maintain some ambient pressure in all tanks and minimize pressure differentials across internal bulkheads. If sudden trim or list develops, tanks may reflood through sea valves, so secure all blowing and close sea valves to maintain intact stability if this should occur.

2. Any change in draft or attitude during venting is an indication that a sea valve has not closed properly.

Step 18. Combined Wing and Pontoon Tank Blowing

INITIAL CONDITION: Maximum draft: 29 feet.
Minimum draft: 20 feet.

OPERATIONS

- a. Check that all pontoon tank vent/blow valves are in closed position.
- b. Monitor manifold pressures continuously, and observe blowing limitations.
- c. Blow remaining (primary) wing tanks in combination with the four primary pontoon tanks. Open wing tank blow valves first, in order to reduce manifold pressure before pressurizing pontoon tanks.
- d. Control trim and list by closing primary pontoon tank blow valves as necessary, observing blowing limitations.
- e. When escaping air, and wing tank manifold pressure drop, indicating that remaining primary wings are empty, secure blowing. Do not vent pontoon tanks.
- f. Close remaining wing tank sea valves, and vent to atmosphere, as in Step 17i.

REFER TO

Sect II, Fig. 6.

Step 19. Pontoon Tank Blowing

INITIAL CONDITION: Maximum Draft
Minimum Draft

OPERATIONS

REFER TO

- a. Monitor manifold pressures continuously.
- b. Observe blowing limitations.
- c. Blow remaining pontoon tanks until desired draft and attitude are reached. It is recommended that a minimum number of pontoon tanks be blown slack while main deck is submerged, so as to maintain maximum transverse and longitudinal stability. After the main deck has emerged, more tanks may be blown simultaneously to obtain the maximum ballast discharge rate.
- d. When desired draft and attitude are reached, secure blowing. Close all pontoon tank sea valves. Position all vent/blow valves to vent. Wait for all tanks to vent to atmosphere, and observe that draft and attitude remain constant.
- e. Crew may now have free access to any part of the vessel.
- f. Drain wet locks, and open inboard wetlock doors and O2 level hatches.

V. DAMAGE CONTROL

INTRODUCTION TO DAMAGE CONTROL SECTION

The damage control section describes various casualties which may occur during CB operation. The scope of the section has been limited as follows:

Casualties described are limited to those which are peculiar to the intended function of the vessel, i.e. a submergible recovery vessel.

Malfunctions and casualties are excluded when their correction fall within the capabilities of competent marine personnel.

While equipment failure correction is included, equipment malfunctions are not. The operator is referred to the technical manuals for equipment troubleshooting information.

Each item in this section covers a specific damage condition, except for the first four. The first four items analyze problems which may occur when entering or leaving the control space, with the headings being the operation rather than the problem.

The operators should be thoroughly familiar with the damage control procedures and should be drilled in correcting simulated damages. In case of a real damage situation, there may not be time to consult this manual.

EQUIPMENT FAILURE SUMMARY TABLE

FAILING COMPONENT	CONSEQUENCES	REMEDIES
Ballast air compressor, one.	Reduced blowing times	None required
Ballast air compressor, both. Ballast umbilical. Main supply Pipe on CB.	WB reels and chain winch inoperative. Tanks cannot be blown. Air driven hydraulic pump becomes inoperative.	Repair. See damage control section 6.
Vent umbilical.	Control spaces go hyperbaric. Electrical power to CB automatically cut. Both hydraulic pumps become inoperative.	Repair. See damage control section 6. If repair is impossible, CB surfacing may be accomplished as described in section 10.
Fluidic umbilical.	Fluidic and pneumatic systems on CB becomes inoperative.	Install cross connection from ballast air on CB. See damage control section 8.
Electrical umbilical.	Electrical system on CB becomes inoperative. Electrical driven hydraulic pump becomes inoperative. Remote valve control system for variable tanks does not work.	Emergency surfacing procedure as described in damage control section 10.
One generator set.	No standby capacity.	None required.
Both generator sets or distribution panel.	No power on either WB or CB. See also electrical umbilical failure.	Obtain 440 VAC power from tug if possible. See damage control section 10.
Constant pressure air compressors, one.	No standby capacity.	None required.

EQUIPMENT FAILURE SUMMARY TABLE - Continued

FAILING COMPONENT	CONSEQUENCES	REMEDIES
Constant pressure air compressors, both.	No constant air pressure on WB. Alarm sounds. Chain winch brake may fail. See also fluidic umbilical failure.	Install cross connection from ballast air on WB.
Air driven or electrical driven hydraulic pump	Reduced standby capacity.	None required.
Both hydraulic pumps	No hydraulic pressure on CB. L. P. alarms sound.	See damage control section 9.
Sea water pump on WB.	CB control spaces may get uncomfortably hot.	Rig spare pump if available. Keep both ballast air compressors on line, control for alternate cycling, loading each compressor for about 5 minutes.

ALARM CONDITIONS

ALARM DESIGNATION	LOCATION			WARNING CONDITION	REQUIRED ACTION
	STBD CONT SPACE	PORT CONT SPACE	WORK BARGE		
Hydraulic system low pressure, port and stbd	X	X	X	Pressure drops to 1000 psi stbd, 900 psi port	See damage control section 9.
Instrumented variable tank high pressure, alarm, 4 tanks	X		X	Tank pressure 40 feet or higher	Manually throttle ballast air supply or open tank vent.
Trim tank high pressure alarm, 4 tanks	X		X	Tank pressure 40 feet or higher	Manually throttle ballast air supply or open tank vent.
High bilge water alarm, port and stbd	X	X	X	Bilge water level 3-6" high	Pressurize control space.
Control space pressure alarm, 2 sensing stbd side, 2 sensing port side			X	Control space pressure, 3 psi sounds alarm, 10 psi cuts off power to CB	Before power is cut off, insure that sea valve is open and vent valve is closed on all flooded tanks.
L. P. Constant air alarm			X	Constant air pressure drops to 90 psi	Manually set chain winch brake or chain stopper.

1. ENTERING ATMOSPHERIC CONTROL SPACE

Refer to Figure 4.

PROBLEM	CAUSE	CHECK AND CORRECTION
<p>Outboard wet lock door will not open</p> <p>Comment: Wet lock pressure will normally be slightly higher than ambient water pressure, making it easy to open door.</p>	<p>1. Wet lock pressure is below ambient water, either because air is not being supplied through valve A or because air is leaking from wet lock to control space</p> <p>2. Door is sticking or is malfunctioning mechanically.</p>	<p>1. Check: Open valve "C". Air bubbles do not emerge. Water flows into wetlock.</p> <p>1. Correction: (a) Hold valve open until inward waterflow stops. Open door. (b) In case of large leak, flow through valve "C" will not equalize pressure. Close valve to avoid flooding control space. Diver surfaces and control space is pressurized to water depth, see Figure 5.</p> <p>2. Check: Open valve "C". Air bubbles emerge. Close valve.</p> <p>2. Correction: Attempt entry through inboard door. Pry either door open with suitable tool if necessary.</p>
<p>Wet lock door or piping to sea leaks</p>	<p>Bad gasket or mechanical malfunction.</p>	<p>Check: When valve "D" is opened to equalize wet lock and control space pressures, water level in lock will rise.</p> <p>Correction: If door cannot be closed, or leak fixed, any stay in the control room must be limited to the time available before water reaches bottom of control space hatch coaming. If leak is large, control space must be pressurized to water depth before entering. Leak detection: Open valve "G", close valve "B", (sealed open). Close wet lock door, (continued next page)</p>

I. ENTERING ATMOSPHERIC CONTROL SPACE

Continued

PROBLEM	CAUSE	CHECK AND CORRECTION
		<p>open valve "A" until GA-19 reads about 3 psi. Exit through door and close it. Inspect outside of lock for air leaks while air supplied through valve "A" expels the water out through valve "G". After leak has been found, undog door, close valve "G" and let air pressure in lock push door open and refill lock with water. Open valve "B" and reset valve "A" to throttling position.</p> <p>CAUTION: Do not reclose valve "G" until door is completely undogged and bubbles emerge around door edge.</p>
<p>Control space hatch will not open</p>	<p>Wet lock pressure higher than control space pressure after valve A has been closed and valve D opened</p> <p>Mechanical malfunction</p>	<p>Check: GA-18 indicates difference between pressures. Correction: Pressurize control space slightly, see Figure 5.</p> <p>See also "Wet lock hatch and piping to sea leaks", above. Water leaks into wetlock may make it impossible to open control space hatch.</p> <p>Ascend until 03 level is dry, enter through topside hatch.</p>

2. LEAVING ATMOSPHERIC CONTROL SPACE

Refer to Figure 4

PROBLEM	CAUSE	CHECK AND CORRECTION
Control space hatch will not close on exit	Mechanical damage or malfunction	Pressurize control space to ambient water pressure, using ballast air direct space supply, Figure 5. Exit, leaving control space hatch open. Time to pressurize is 8 minutes at maximum depth.
Wet lock door will not open	Slight underpressure in wet lock. Mechanical damage or malfunction	Open valve "A" more, until air is definitely exhausting through valve "B". Use inboard door.
Wet lock door will not close on exit	Mechanical damage or malfunction	Leave it open.
Emergency escape, wet lock inoperative	Severe damage	Close control space hatch to wet lock. Undo O3 level hatch, close control space vent, open direct space supply and let space pressure open hatch. Space will fill with water up to lower edge of hatch trunk and hatch trunk will be full of water. If entry into hyperbaric control space through the damaged wet lock may be possible, close direct space supply, exit, and close hatch. Space will empty of water automatically. or Leave space supply open, exit and leave hatch open. Re-entry of control space will be required to save CB.

3. ENTERING HYPERBARIC CONTROL SPACE

Refer to Figure 4

PROBLEM	CAUSE	CHECK AND CORRECTION
<p>Outboard wet lock door will not open</p>	<p>1. Wet lock pressure is below ambient water, because of any two of the three causes listed: (a) Valve "A" is closed completely. (b) Valve "F" is closed. (c) Control space pressure is below ambient water pressure.</p> <p>2. Door is sticking or is malfunctioning mechanically</p>	<p>1. Check: Open valve "C". Air bubbles do not emerge, water flows into wetlock.</p> <p>1. Correction: Diver returns to surface and requests check of control space pressure. Note that valve "F" being closed will cause excess control space pressure under hyperbaric conditions.</p> <p>If control space is hyperbaric, but wet lock is not, diver returns, opens valve "C" until inward waterflow stops, opens door and enters.</p> <p>2. Check: Open valve "C". Air bubbles emerge. Close valve.</p> <p>2. Correction: Attempt entry through inboard door. Pry either door open with suitable tool if necessary.</p>
<p>Control space hatch will not open</p>	<p>1. Control space pressure lower than wet lock pressure</p> <p>2. Mechanical malfunction</p>	<p>1. Check: GA-18 will indicate pressure differential.</p> <p>1. Correction: (a) Close valve "A" until the wet lock pressure is definitely below control space pressure. Open hatch and reset valve "A". (b) Increase control space pressure, using direct space supply, see Figure 5. This must be done from WB.</p> <p>2. Ascend until 03 level is dry, enter through topside hatch.</p>

4. LEAVING HYPERBARIC CONTROL SPACE

Refer to Figure 4

PROBLEM	CAUSE	CHECK AND CORRECTION
Control space hatch will not close on exit	Mechanical damage or malfunction	Leave open. Open wet lock door and direct space supply, blowing water level down to hatch coaming. Close direct space supply, exit and close wet lock door. Subsequent entry to control space is only possible with space hyperbaric.
Wet lock door will not open	<p>1. Wet lock pressure is below ambient water</p> <p>2. Mechanical damage or malfunction</p>	<p>1. Check: Does gauge GA-19 show wet lock underpressure. If so, is air emerging from valve "A" and from the discharge line from valve "F".</p> <p>1. Correction: If air is not emerging as listed, open valves "F" and "A".</p> <p>Use inboard door.</p>
Wet lock door will not close on exit	Mechanical damage or malfunction	Leave it open.
Emergency escape because wet lock is inoperative	Severe damage	Identical to "2. Leaving atmospheric control space".

5. CONTROL SPACE FLOODING

CAUSE	INDICATION	CORRECTION
Leak at or near O2 level	Bilge alarm is energized. Calculation of maximum height of water, in control space, h feet: $h = 11 - \frac{233t}{d+33}$ where t is stop watch reading in minutes and decimal fraction of minutes, d is depth of O2 level in feet. (depth indication-51 ft). Both ballast compressors operating. With one compressor only operating use: $h = 11 - \frac{116t}{d+33}$	Open direct space supply and close space vent. Start stopwatch. When space pressure equals ambient water pressure, stop the watch. Monitor space pressure closely. It must not exceed 40 feet above ambient water pressure. Close and reopen space supply if necessary. When bilge alarm goes off, close space supply. Disconnect all electricity to CB and send diver down to investigate. CAUTION: If water level reaches solenoid valve controlling direct space supply valve, it may not be possible to shut off supply. To avoid space overpressure, ballast air supply must then be controlled at surface ship root valve.
Leak above O2 level	Bilge alarm is energized. Calculation of maximum water height as above.	Identical to above, but bilge alarm will remain energized. Space has been emptied to minimum water level and space supply maybe closed when substantial amount of bubbles emerge at surface.

6. BALLAST AIR SUPPLY TO CB CUT OFF

Refer to Figure 1

CAUSE	INDICATION	CORRECTION
Ballast hose kinked. Valve in main supply line left closed. (valve E or F)	Ballast compressors do not cycle on. No air exhaust from vent hose.	Diver goes down to investigate and correct. It may be necessary to pay out chain to correct a kink.
Ballast hose broken	Ballast compressors keep running at full speed. Large amount of air surfaces in way of break	<p>Insure that vent to tank 2-20-1-S is open. Shut off ballast air supply, valve "C". If possible retrieve hose up to broken section and replace on surface. Alternatively send divers, two minimum, down for underwater replacement.</p> <p>Remove water from hose and main as follows: Increase tension on chain to CB until it leads off fan tail at a 5° angle with the horizontal. Open breakout system control valve and blow until air emerges on surface. Shut off air supply on surface.</p> <p>Diver opens drain valve "D" and removes plug above vent terminal in tank 2-20-1-S. Surface personnel opens ballast air supply for about 10 minutes. Close drain valve and replace pipe plug.</p>
Both ballast air compressors inoperative	No ballast air pressure on WB.	Repair or replace at least one compressor.

7. VENT UMBILICAL BLOCKED

Refer to Figure 5

CAUSE	INDICATION	CORRECTION
Vent hose kinked. Valve in vent line left closed. See Fig. 5	No air exhaust from vent line. Control space pressures climb.	Diver goes down to investigate and correct. It may be necessary to pay out chain to correct a kink.
Water in vent hose, or in vent main	Same as above, but diver finds no visible blockage.	Insure that vent to tank 2-20-1-S is open. Rig connection from surface ship vent hose terminal to ballast system air supply. Diver enters both control spaces, closing valve "E". Removes pipe plug above tank vent terminal, see Fig. 6. Next drain valve "D" is opened and hose is pressurized to 100 psi for about 10 minutes. Increase tension on chain to CB until it leads off fan tail at a 5° angle with the horizontal. Close valve "D", and replace plug, but leave pressure on umbilical hose while inspecting for leaks. Repair as required.
Vent hose broken	Initially, air escapes in way of break. As hose fills with water, indication becomes same as above.	If possible, retrieve hose up to broken section and replace on surface. Alternatively, send divers, two minimum, down for underwater replacement. After repair, procedure is similar to "water in vent hose" above.

8. FLUIDIC AND PNEUMATIC SYSTEMS INOPERATIVE

Refer to Figure 2.

CAUSE	INDICATION	CORRECTION
Fluidic umbilical destroyed	Air emerges in way of break. Fluidic system becomes inoperative.	<p>Close valve "E" and install cross connection in stbd control space between 1/2" NPT connection on constant pressure air, and ballast air service outlet, Fig. 1. Suitable hose to be stored in control space. Referring to drawing 7043-21, sheet 2, fluidic system, open valve from bladder accumulator to space and close valve between the two manometer legs. This results in the following condition:</p> <ol style="list-style-type: none"> 1. WB fluidic system becomes inoperative. 2. CB fluidic system remains operational provided ballast air pressure exceeds 60 psi. System accuracy is reduced. System becomes grossly inaccurate at air supply pressure less than 60 psi. Pneumatically actuated valves will operate with 40 psi air supply. <p>Close constant pressure air root valve "C" at umbilical on WB.</p>
Constant pressure air unavailable on WB due to electrical failure or similar	Constant pressure L. P. alarm on the WB sounds	<p>Provide cross connection from ballast air on WB. Suitable hose to be stored in accessible location. No fluidic system deterioration with pressure above 90 psi. Some inaccuracy with air pressure 60-90 psi, gross inaccuracy below 60 psi air supply.</p> <p>Pneumatically actuated valves are similar to "Fluidic Umbilical Destroyed" condition.</p> <p>When WB constant pressure air alarm sounds, immediately insure that mechanical chain stopper is set, otherwise chain may start running out.</p>

9. HYDRAULIC SYSTEM INOPERATIVE

Refer to Figure 3

CAUSE	INDICATION	CORRECTION
Total system failure due to main supply line destruction, or similar	Hydraulic pressure unobtainable. Alarm sounds on WB and in both CB control spaces.	Where sea valves were left open after flooding, flooded tanks may be blown again. Trim system will be inoperative. Blow tanks as required to ascend to surface and repair. Keep tanks with open sea valves empty by intermittent, short duration blowing.
Failure of supply system due to loss of reservoir, suction main or similar	Neither pump will deliver oil. Alarm sounds as above.	If failure is discovered at 2000 psi pressure, approximately 600 cu. in. of oil stored in accumulators will be available, sufficient for stroking one valve 43 times. If failure is discovered at 1000 psi alarm setting, approximately 280 cu. in. is available, sufficient for 20 strokes. Blow flooded tanks, close all pontoon tank sea valves and as many wing tank sea valves as possible. Keep tanks with open sea valves blown empty. Repair.
Either pump fails	Pump does not start	None required. The electrical and the air driven pump each has the capacity to handle 16 valve strokes per minute.

10. ELECTRICAL POWER TO CB CUT-OFF

Refer to Figures 7 and 13

CAUSE	INDICATION	CORRECTION
<p>Electrical umbilical destroyed</p>	<p>On CB, all electrical equipment goes dead. On WB all indicating lamps from CB goes off.</p>	<p>Trip breakers to CB power. The breaker is located in the compressor/generator station on the WB.</p> <p>If the CB is on surface, blow flooded tanks. Variable tanks are blown as follows, referring to Fig. 7: If sea valves are closed, solenoid operated hydraulic valves, valve "E", are shifted manually by pushing on rod through hole in end of solenoid, using small screwdriver. Blow valves are opened by shutting off the air supply to each pneumatic valve panel, valve "K", and manually shifting the solenoid operated butterfly valve "G".</p> <p>If the CB is on the bottom, man both control spaces. Select tanks, including cylinders which when blown, will result in a small negative buoyancy. Shift the hydraulic and pneumatic operated sea and blow valves as above, and blow the selected tanks. Next, cut off the ballast air supply on the WB and select tanks which when blown will result in emergence of the 03 level. This should preferably be the instrumented variable tanks. Manually position the blow valves and hydraulic sea valve control valves to open as before. Unman control spaces. Open ballast air supply on the WB, which will start the blowing. Throttle the ballast air supply, and as soon as the depth indicator shows that surfacing has started, shut ballast air off. Wait until ascent stops, then continue to blow slowly, gently bringing the CB to the surface.</p> <p>Re-man control spaces, close empty tank blow and sea valves. Blow remaining variable tanks and soft tanks. Close all sea valves and open all vent valves.</p>

11. CYLINDER FLOODS ACCIDENTALLY DURING SUBMERGENCE

Refer to Figure 9.

CAUSE	INDICATION	CORRECTION
Sea valve left open	Sea valve position indicated by light. Water level indicated by water level and angle indicator.	Blow out water, close sea valve.
Leak		In case of leak, water can only be blown out to the level of the leak.

12. CYLINDER BLOWN ACCIDENTALLY ON BOTTOM

Refer to Figure 9

CAUSE	INDICATION	CORRECTION
Blow valve inadvertently opened.	Blow valve position indicated by light. When sufficient water has been expelled for the cylinder to tilt, this is indicated by the water level and angle indicator.	Close blow valve, open sea valve and vent valve.
Blow valve leaks.		
NOTE: Blow valve cannot be opened without also opening flood valve.		

13. CYLINDER CANNOT BE BLOWN ON BOTTOM

Refer to Figure 9

CAUSE	INDICATION	CORRECTION
No ballast or constant pressure air	See damage control items 6 or 8.	See damage control item 6.
Hydraulic failure	See damage control item 9.	See damage control item 9.
Hydraulic hose to flood valve fails	Loss of hydraulic oil. Oil slick shows on surface. Alarm sounds. Valve indication shows valve "closed".	Cut ballast air supply and electric power to CB to stop both hydraulic pumps. Divers go down to: (a) Repair leak if possible, or (b) Plug broken hose end toward control station, and (c) Enter control station to check reservoir oil level, refill if required.

14. CYLINDER CANNOT BE FLOODED ON BOTTOM

Refer to Figure 9

CAUSE	INDICATION	CORRECTION
Hydraulic failure or hydraulic hose to flood or vent valve fails	See damage control item 13.	See damage control item 13.

15. BALLAST TANK DOES NOT BLOW

Refer to Figures 6 and 7

CAUSE	INDICATION	CORRECTION
(a) <u>Any tank</u>		
No ballast air		See damage control item 6.
Hydraulic failure, sea valve system inoperative		See damage control item 9.
Failure of one sea valve to open	CB will take on unexpected list and/or trim.	<p>Determine which tank is not blowing as follows:</p> <p>(a) Estimate by list and trim indication.</p> <p>(b) Close all blow valves.</p> <p>(c) Open blow valves to tanks, one by one in order of decreasing probability. Check effect per (d) below, then close each valve.</p> <p>(d) When faulty tank has been found, blowing will have no effect on vessel attitude. When tank pressure reaches overprotection valve setting, ballast air flow will stop.</p> <p>If a variable tank is at fault, leave it full while compensating by not blowing diagonally opposite variable or wing tanks.</p> <p>If a soft tank is not blowing, manually open the emergency drain and evacuate the tank through an adjacent tank. See Figure 20.</p>
(b) <u>Variable tank</u>		
Failure of one blow valve to open. See also Electrical failure, item 10.	CB will take on unexpected list and/or trim.	<p>Determine which tank is not blowing as follows:</p> <p>(a), (b), and (c) as above.</p> <p>(d) When faulty, closed valve has been found, ballast air flow will stop. Manifold pressure will equal depth of tank water level. Correct per damage control item 10.</p>

16. BALLAST TANK DOES NOT FLOOD

Refer to Figures 6 and 7

CAUSE	INDICATION	CORRECTION
(a) <u>Any tank</u>		
Hydraulic failure, sea valve system inoperative		See damage control item 9.
Failure of one sea valve to open	CB will take on unexpected list and/or trim.	If still submerging, resurface and repair. If on the bottom, do nothing.
(b) <u>Variable tank</u>		
Electrical failure, variable tank vent and sea valves inoperative		See damage control item 10.
One vent valve does not open	Similar to "Failure of one sea valve to open", above.	

Section VI
HYDROSTATIC CHARACTERISTICS
AND CALCULATIONS

A. General

Design Features. The general arrangement of the CB and the hydrostatic loadings used for structural design were based on a sequence of flooding which started with the tanks located near the bottom of the vessel and proceeded upward. The void spaces in the uppermost part of the vessel, without means of flooding, were made small enough so that the light vessel, without payload, could still be submerged.

Constraints on Ballasting Sequence. The ballasting sequences described in this section and in Section III are based on the following design and operating constraints.

- * The CB must maintain positive transverse and longitudinal stability at all times to preclude sudden capsizing.
- * The design structural loadings must not be exceeded.
- * Vessel attitude (trim and list) must be kept within reasonable limits.
- * The ballast conditions used must be ones which the operator can attain using the instrumentation or other visible or audible indications available to him.
- * The operations needed to accomplish submerging or raising should require the minimum elapsed time.

- * Calculations needed to predict or check the condition of the vessel should be kept to a minimum. Where needed, they should be simplified so as to conserve time and minimize the possibility of error.

When to Perform Calculations. Calculation forms for soft tank ballasting conditions are provided. The calculations are to be performed in the conventional manner. With experience, however, it should be possible to operate the vessel on the surface without extensive planning or calculation of the various intermediate stages of flooding, provided that the guidelines given in this section are followed.

Hard tank ballast arrangements for each submergence should be planned in advance, particularly when payload condition is to be changed while submerged. Generally, there are many possible tank arrangements for a given payload. With careful planning, an efficient sequence can be selected and elapsed time for the operation can be minimized. A well-defined plan will also aid in identifying and counteracting any casualties which might occur.

B. Soft Tank Ballasting

The recommended flooding and blowing sequences for soft tanks are covered in Section C of this manual. In summary:

1. Soft Tank Flooding Sequence

a. Flood all pontoons.

Primary pontoon tanks for attitude control:

2-32-2	2-0-2
2-32-1	2-9-1

Secondary pontoon tanks for attitude control:

2-43-2	2-3-2
2-43-1	2-3-1

b. Combined pontoon and wing flooding: Flood primary (or secondary) wing tanks diagonally opposite from unfilled primary (or secondary) pontoon tanks.

c. Flood all wing tanks.

Primary wing tanks for attitude control:

2-43-4	2-3-4
2-43-3	2-3-3

Secondary wing tanks for attitude control

2-32-4	2-9-4
2-32-3	2-9-3

d. Flood remaining tanks used for attitude control in combination with hard tanks and/or trim transfer.

2. Blowing

Due to restrictions on the minimum number of soft tanks which may be blown simultaneously, blowing is not precisely the reverse of flooding. Note restrictions in Section III.

Primary and secondary groups of wing tanks and pontoon tanks for attitude control are the same as for flooding. However, other tanks must be blowing at all times so as not to violate restrictions.

a. When all symmetric pairs of hard tanks are blown, and trim ballast transferred as necessary, board CB.

b. Blow remaining hard tanks in combination with all wing tanks. Close blow valves on not more than four primary (or secondary) wing tanks at one time, as needed for attitude control.

- c. When at least four wing tanks are blown completely, start blowing at least two pontoon tanks. Then wing tanks may be secured when blown completely.
- d. When all wing tanks are empty, start blowing all pontoon tanks, then secure wing tank manifold and individual wing tanks. Control attitude by closing blow valves on primary (or secondary) pontoon tanks only, until desired surface condition is reached.

NOTES: Observe proper sequence for securing tanks, as given in Section C of this manual.

Always blow as many tanks as possible simultaneously. This will ensure compliance with restrictions, and will conserve compressed air, thereby minimizing elapsed operation time.

3. Tank Capacity Curves

Net tank capacity curves are given on the following pages, for use as necessary in hydrostatic calculations.

4. Calculation Forms

Sample hydrostatic calculation forms are given on the following pages. Characteristics of full soft tanks are given. Characteristics of partially full tanks may be obtained from tank capacity curves. Curves of form (contract plan No. 7043-2, Sheets 1 and 2) are needed for any hydrostatic calculations, except for conditions where soft tanks are completely flooded.

C. Hard Tank Ballasting

The need for careful planning and monitoring of hard tank ballast conditions dictates a graphical approach to hydrostatic calculations. Conventional calculations using curves of form and tank capacity curves may also be performed if desired. But, in general, the following diving polygons and overlays can be used more conveniently.

Contract Dwg No.	7043-4;	Sht 1,	Long'l	Diving Polygon
"	"	"	"	" (Overlay)
"	"	"	"	" (Overlay)
"	7043-5,	Sht 1,	Transverse	Diving Polygon
"	"	"	"	" (Overlay)

The "Polygon Reference Tables", Appendix A, are required to identify coded points on the polygons.

1. Guidelines

The following considerations should be kept in mind when planning tank arrangements. The extent to which these criteria can be met will depend on the individual case. Obviously, payload with a size and location which approaches the carrying capacity of CB cannot be supported with the same reserves against casualties as can smaller or more favorably located payloads.

Trim System Charge. The most convenient trim system weight, both for charging and for use, is 50 per cent. Payload capacity can be extended (in terms of weight, but not necessarily moment) by reducing the charge. A 25-percent charge is also convenient, but does not provide as much trimming capacity. The vessel can theoretically be operated with the trim system empty, but this makes control of the diving operation more difficult.

Trim system distribution. If other constraints are not compromised, it is desirable to distribute trim ballast equally. If this is not practical, attempt to leave at least a small amount of reserve for trimming in any direction for critical stages such as final cylinder submergence.

IVB Tank Levels. Attempt to fill IVBs partially. Any completely full or completely empty tank limits the operator's ability to make fine adjustments to the diving plan during the operation. Other VB tanks may of course be used for fine adjustment, but only the IVBs provide data to determine the magnitude of any errors in the diving plan which might be accounted for in subsequent dives.

Symmetric Diving Tanks. Submerged operation (diving or ascending) will be simplified if this stage of the operation is accomplished with symmetric sets of four or more tanks at a time. The symmetric tank pair combinations of sufficient capacity to dive from the 03 WL to the cylinder depth WL are

06, 09, 40, and 43 P/S
16 and 32 P/S
20 and 28 P/S

Tank combinations containing one or more of these groups are identified on the polygon and will be discussed further.

The IVB tank group, 12 and 36 P/S, also have sufficient capacity for diving. A secondary possibility for diving groups, which are nearly symmetric, but will require slight trim corrections during diving, are

06, 25, and 43 P/S
09, 25, and 40 P/S

since tanks 25 P/S are located slightly aft of amidships.

2. Description of Diving Polygons and Overlays

a. Longitudinal Polygon

Coordinates. The longitudinal polygon is a graphical description of the ballast weights (vertical axis, long tons) and moments (horizontal axis, long ton feet) of various combinations of filled variable ballast tanks (VBs).

Sign conventions. The vertical scale of increasing ballast weights is plotted downward. The horizontal scale of increasing forward ballast moment is plotted to the left, and aft moments to the right.

Tank pairs. The points on the longitudinal polygon, and in the accompanying "Longitudinal Tank Combination Tables," consider only port and starboard pairs of filled variable ballast tanks. Values on the overlay are for the average of port and starboard levels in transverse pairs of instrumented variable tanks (IVBs) and trim tanks.

Lines. Each of the eighteen VB tanks are of equal height and width. Ten of the tanks are 18 feet in length, and the other eight are 24 feet in length. This results in 26 possible values of weight in filled P/S pairs of VB tanks. Each possible weight is represented by a horizontal line on the polygon. The line is identified by its VB weight in long tons.

Points. All of the possible longitudinal moments associated with possible tank pair combinations

of the proper weight are plotted as individual points along each line. Since labelling of each point with its tank combinations would be cumbersome, points are numbered consecutively from left to right. The one or more combinations, which can be used to obtain the weight and moment of a given point, may be found in the longitudinal tank combination tables. First, turn to the page in the tables corresponding to the line number. VB tanks associated with the point are listed, using the frame identification number.

Attitude. The relationship of ballast arrangement to draft and payload characteristics as described below, assumes "level equilibrium", or zero trim. Other than level conditions may be treated, however, if the longitudinal stability characteristics are known, by measuring the imbalance of longitudinal moments from the polygon.

Trim system charge. The polygon scales and overlays have been prepared for the condition where the trim system is charged to 50 per cent capacity. Other conditions can be treated by preparing additional overlays.

Relationship to draft, without payload. A vertical scale of CB keel draft is given on each margin of the polygon, with draft increasing downward. If no payload is being carried, trim system is charged to 50 per cent, and IVBs are empty, then the draft may be read directly from the weight of the filled tank combination by moving horizontally to the draft scale on the margin.

If the IVBs are not empty, place the upper origin of the overlay on the point corresponding to the combination of filled VBs. Then mark the point on the inner diamond region of overlay corresponding to the IVB tank levels. The draft may then be found by moving horizontally from this point to the draft scale.

The draft scale is essentially a plot of CB displacements (in long tons) for each draft. For any VB tank condition, the sum of light ship weight, net soft tank ballast weight, trim system weight, and VB tank ballast weight is equal to the CB displacement for vertical equilibrium. The draft at which this CB displacement occurs is plotted opposite the VB tank condition point.

Definition of Payload Weight. Note that we can treat only the "wet" payload weight, or the weight in air minus any buoyancy. (For a steel structure which floods completely, the wet weight is 87 per cent of the dry weight. For payloads with other materials or with watertight spaces, buoyancy must be calculated.)

Relationship to draft, with payload. In this case, the sum of light ship weight, net soft tank ballast weight, VB and IVB tank weights, trim system charge, and wet payload weight, must equal the CB displacement at the equilibrium draft. All terms of the equation except payload weight are included in the geometry of the polygon, overlay, and draft scale. The payload

weight may be added graphically by transferring the corresponding vertical distance from the payload scale in the margin.

Longitudinal Origin. Note that the vertical line through the polygon, corresponding to zero on the payload moment scale, is not at the center of the polygon envelope. This results from the longitudinal asymmetry of the vessel. The light ship center of gravity is forward of amidships, and VB tanks 25 are aft of amidships. The vertical line, and moment scales, have been located such that if the graphical sum of VB moment, IVB moment, trim system moment, and payload moment lies on the line, the vessel will be in level equilibrium.

Symmetric Diving Tanks. The groups of symmetric VB tanks which are of sufficient capacity to be used for diving were given in the guidelines. For ballast conditions fully submerged, it is preferable to have one such group filled (unless it is feasible to use the IVB group for diving). Tank combinations which contain such groups are identified by their point symbol on the longitudinal polygon:

⬆ symbol is used for combinations with symmetric diving groups.

⬇ symbol is used for other combinations.

In the reference tables, any tanks which form a symmetric diving group, or groups, are underlined.

b. Transverse Polygon

Relationship to Longitudinal Polygon. Note that if transverse moments of the vessel and payload are negligible, and only P/S pairs of tanks are filled, then only the longitudinal polygon need be used. However, it is necessary to use both polygons to treat a condition involving transverse moments. To make the two truly independent would have required a much more complex longitudinal polygon.

Coordinate Axes. The transverse polygon is also a plot of the weights and moments associated with various combinations of filled VB tanks. Weight is plotted on the vertical scale, increasing downward. Transverse moment, about the CB centerline, is plotted on the horizontal scale, with starboard ballast moments to the left and port ballast moments to the right.

Lines. Horizontal lines are again identified by the total VB weight. More lines appear on this polygon, since we must represent all the weight combinations of ten small tanks and eight large tanks, rather than the five pairs of small tanks and four pairs of large tanks represented on the longitudinal polygon.

Points. Each point on a line represents a transverse moment which can be obtained using a combination of filled VB tanks whose total weight equals the line number. The points are numbered from left to right, for reference to the "Transverse Tank Combination Tables". In

the transverse tables; it is not necessary to identify individual tanks by frame number. All tanks have the same transverse moment arm; therefore, the transverse tables merely give the quantities of large and small tanks filled on each side.

Symmetric and skew tanks. For complete level equilibrium, an arrangement of filled VB tanks, and levels in IVB and trim tanks, must be found which result in equality of both transverse and longitudinal moments. In order to find the simultaneous solution, consider any VB tank arrangement to be made up of some number of filled P/S symmetric pairs and some number of additional filled tanks, for which the tank on the opposite side is not filled (skew tanks). The weight and longitudinal moment of the symmetric tank are represented by a point on the longitudinal polygon, which includes all combinations of transverse symmetric pairs. The net transverse moment of the symmetric tanks is zero.

The total weight of all the filled tanks and the total transverse moment (due to skew tanks) are represented on the transverse polygon. In order to represent the additional weight and longitudinal moment of the skew tanks, alternate origins for skew tanks are given on the longitudinal overlay. These alternate origins are again identified by line number (the weight of the skew tanks in long tons) and point. The points are labelled with the frame identification numbers of the skew tanks.

Simultaneous Solution for VB Tanks. To find a combination of VB tanks which will produce nearly level equilibrium at a given draft and payload condition, plot the payload weight and transverse moment on the transverse polygon, measuring from the origin corresponding to the desired draft. Similarly, plot the payload weight and longitudinal moment on the longitudinal polygon.

Place the overlay on the transverse polygon upside down, with the origin on the plotted payload point, to identify the possible solutions. A workable solution must be found by trial and error. Pick a possible solution and look it up in the Transverse Reference Tables. The weights of the symmetric and skew tanks are given in the table, identified as "Long'l Polygon Line No." and "Alternate Origin Line No." Place the longitudinal overlay, also upside down, with the proper alternate origin line on the plotted payload point, and slide it horizontally to test various alternate origins (skew tank longitudinal moments) on that line. For each alternate origin, try to find a point on the proper longitudinal polygon line which is made up of tanks not used as skew tanks. Note that a tank cannot be filled twice! Note also that the other constraints listed previously must be observed (providing symmetric diving tanks, trim reserve, IVB margin, etc.).

If transverse payload moment is large, considerable searching may be required.

Simultaneous Solution, for IVB Tanks. When a promising simultaneous solution for the VB tanks is found, check the required levels of the four IVB tanks. Leave both overlays in place, upside down, as in the previous step. From the transverse overlay, read the average levels of the port pair and starboard pair. From the longitudinal overlay, read the average levels of the forward pair and after pair. There is no unique solution, but a possible solution of tank levels may be found by inspection. Merely select an arbitrary level for one tank which will result in levels between zero and eighteen feet for the other three tanks. A diagram for this purpose is given on the worksheet.

Simultaneous Solution, for Trim Tanks. The trim tank levels may determined, if necessary, in the same manner as described for IVBs above.